

B-2100 ONDA SMARTONE **NEW**

H.15

- Balastra inclinata, regolabile.
- Inclined anti-vertigo railing system, adjustable.
- Verstellbares Railing System im Winkel gegen Höhenangst.

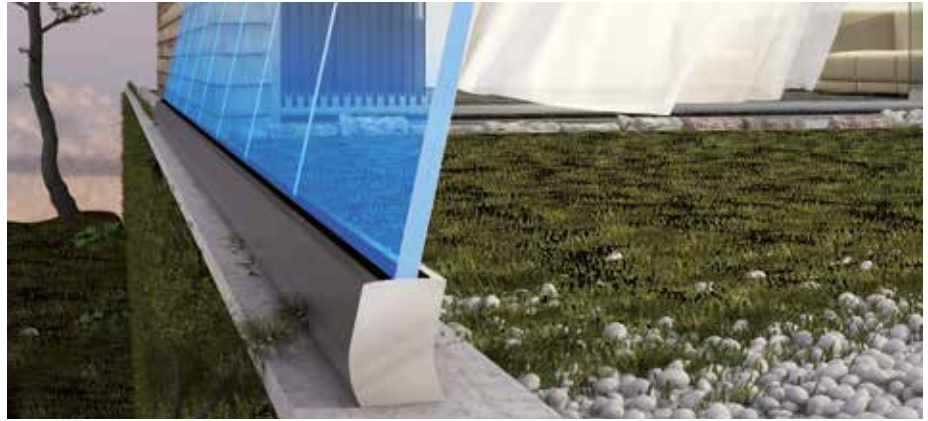

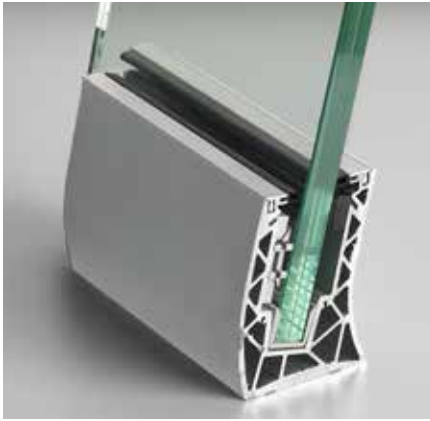

COMPONENTI / COMPONENTS / EINZELTEILE

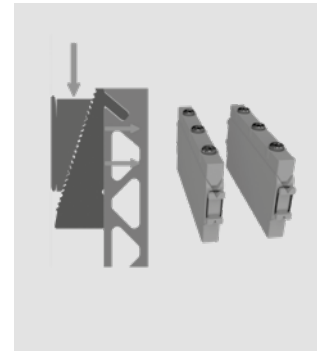
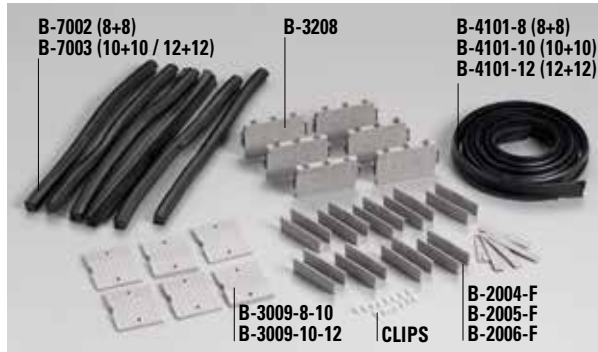
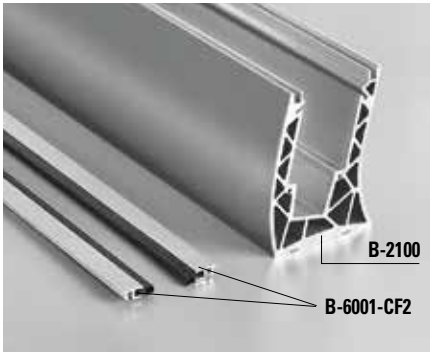

B-2100+B-6001-CF2

- Profilo balaustra + 2 Velette
- Railing profile + 2 Cover profiles
- Profil für Geländer mit 2 Abdeckungen

B-SET SMART 8 / B-SET SMART 10 / B-SET SMART 12

- Set morsetti e guarnizioni
- Set clamps and gaskets
- Set Klemmen und Dichtungen

KIT SMARTONE 2

- Passa dalla regolazione singola alla doppia quando vuoi
- Switch from the single to the double regulation whenever you want
- Auf Wunsch kann jederzeit von der Einzelregulierung auf die Doppelregulierung übergegangen werden

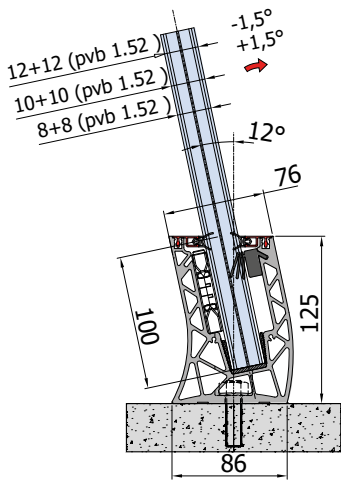

B-2100

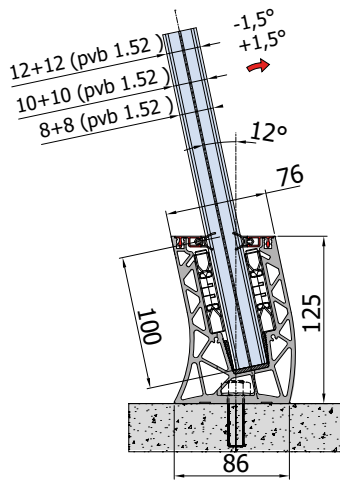

B-2100 + KIT SMARTONE 2

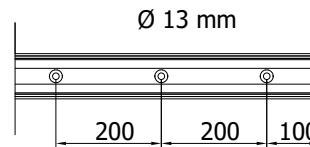

FB041P167

Set completo/mt L = 3000 mm Complete set/mt L = 3000 mm Komplett-Set L = 3000 mm	FIN. FIN. OB.	Vetro Glass Glas	Morsetti/mt Clamps/mt Klemmen/lfm	Testato spinta Test side force Getestete Seitenkraft	Classe Class IT Klasse	Testato Tested Bestätigte horizontale Nutzlast
B-2100-N-3-8	AN	8+8 pvb	2	150 kg	1	1 kN/m = 100 kg/m
B-2100-N-3-10	AN	10+10 pvb	2	300 kg	2	2 kN/m = 200 kg/m
B-2100-N-3-12	AN	12+12 pvb	4	450 kg	3	3 kN/m = 300 kg/m

SET COMPOSTO DA SET CONSISTING OF SET BESTEHEND AUS	FIN. FIN. OB.	B-2100 SET 1,5 KN 8	B-2100 SET 3 KN 10	B-2100 SET 4,5 KN 12
B-2100 + B-6001-CF2	AN	1 pz/pcs L = 3000 mm	1 pz/pcs L = 3000 mm	1 pz/pcs L = 3000 mm
B-SET-SMART-8	-	1	-	-
B-SET-SMART-10	-	-	1	-
B-SET-SMART-12	-	-	-	1