

FRAMED DOOR

V and VL are values only for calculation - *V und VL sind Werte nur für die Berechnung*
 V o VL son trabajos que sirven solo para el cálculo - *V et VL sont des valeurs à des fins de calcul uniquement*

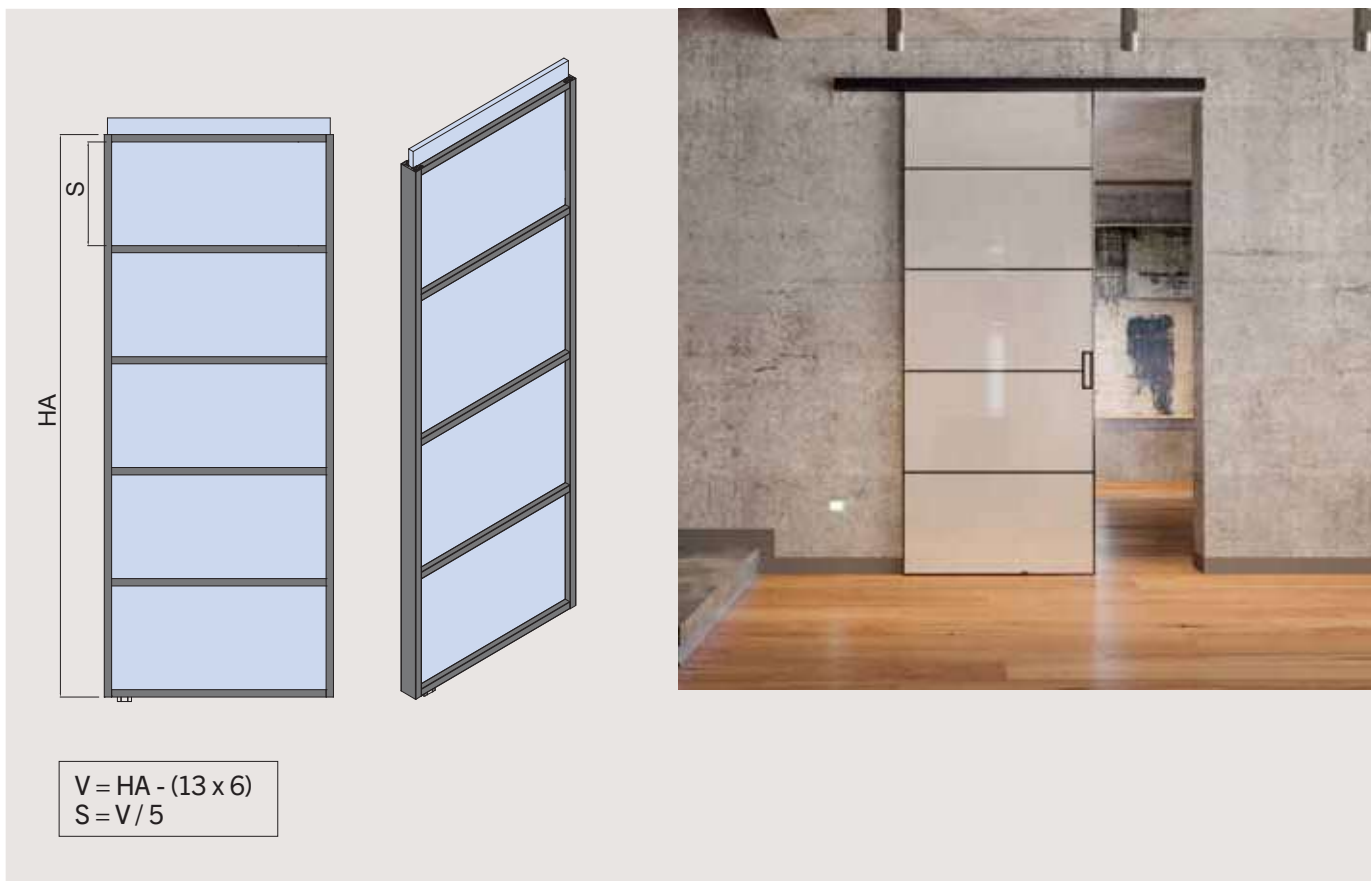

$$V = HA - (13 \times 6)$$

$$S = V / 5$$



$$V = HA - (13 \times 6)$$

$$S = V / 5$$

$$VL = LA - 39$$

$$SL = VL / 2$$

MY METALGLAS

Configure your panel to calculate the cross profiles
 Konfigurieren Sie Ihre Tür und berechnen Sie automatisch die Querprofile
 Componga su puerta para cuantificar los travesaños por encargo
 Composez votre porte pour quantifier les traverses à commander

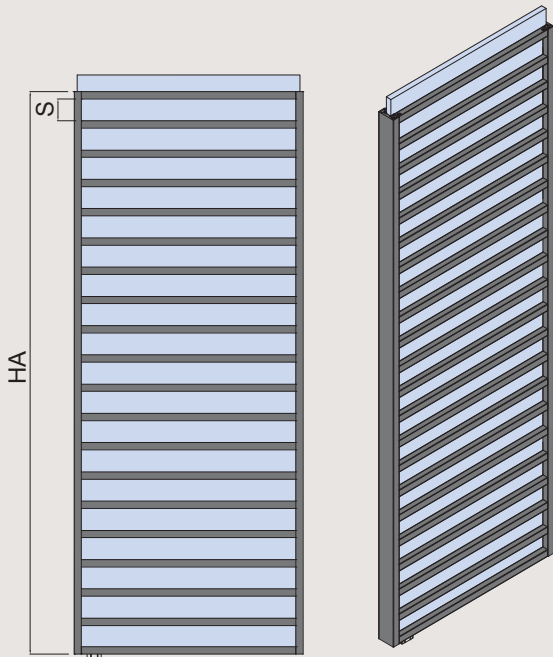

$$V = HA - (13 \times N)$$

$$S = V / (N - 1)$$

N = N° cross profiles - N° Querprofile - Número de transversales - N° de traveseas

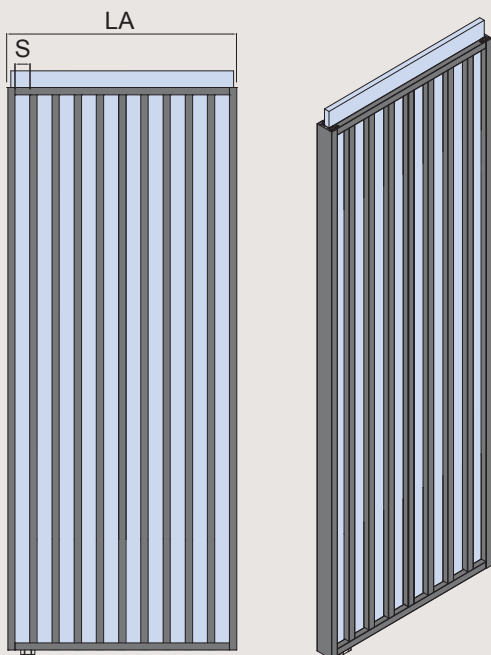

$$VL = LA - (13 \times N)$$

$$S = VL / (N - 1)$$

N = N° cross profiles - N° Querprofile - Número de transversales - N° de traveseas

MY METALGLAS

Configure your panel to calculate the cross profiles
 Konfigurieren Sie Ihre Tür und berechnen Sie automatisch die Querprofile
 Componga su puerta para cuantificar los travesaños por encargo
 Composez votre porte pour quantifier les traverses à commander

ESSENZA - Ri-EVOLUTION

VISIBLE TRACK PROFILES
SICHTBARE LAUFSCHIENEN - RIELES A LA VISTA - RAILS VISIBLES



MY METALGLAS

Configure your system
Konfigurieren Sie Ihr System
Configura tu sistema
Configurer votre système

Sliding system	V-5600	V-5650	V-5700
Max	120 kg	80 kg	120 kg
Soft-close	70-80-100-120 kg (optional)	70-80-100-120 kg (optional)	70-80-100-120 kg (optional)

8/10	8.76/10.76/12 12.76/13.52 with-mil-con-avec V-5607	500 min 1000 max

Ceiling
Decke
A Techo
Plafond

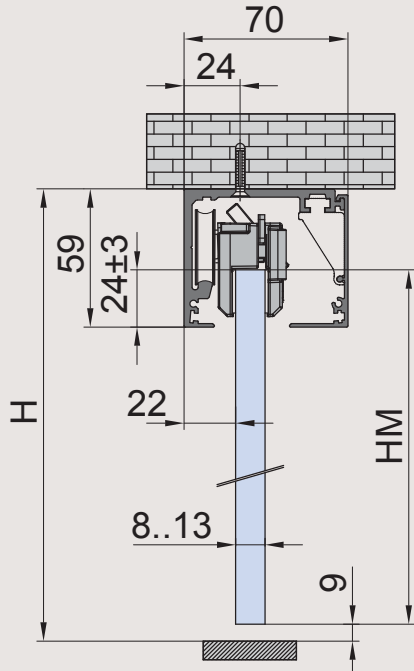

$$HM = H - 44$$

xme576a

Wall
Wand
A Pared
Mur

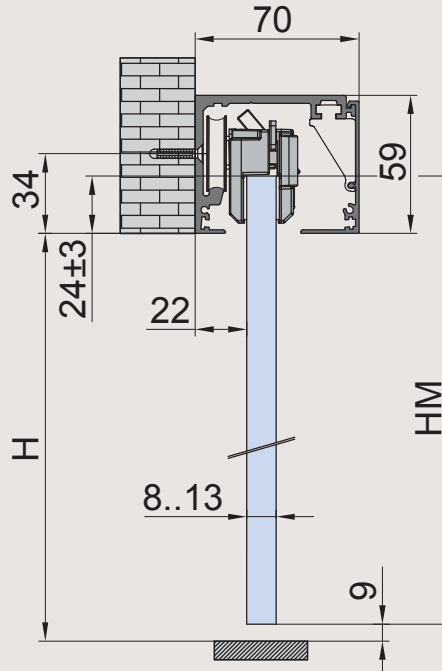

$$HM = H + 15$$

Glass preparation
Glasbearbeitung
Procesamiento de vidrio
Traitement du verre

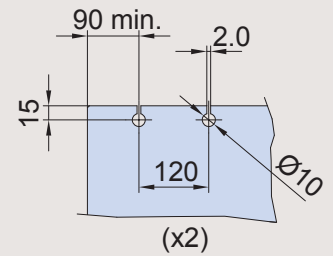

- **Holes optional**
- **Bohrungen Optional**
- **Agujeros opcionales**
- **Trous optionnels**

SET 1

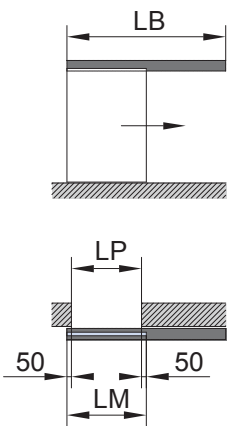

$$LB = LP \times 2 + 150$$

$$LM = LP + 100$$

SET 2

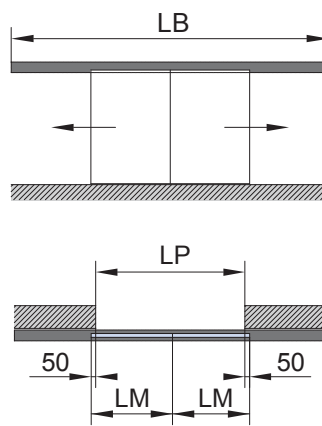

$$LB = LP \times 2 + 100$$

$$LM = (LP + 100) / 2$$

ESSENZA - Ri-EVOLUTION

VISIBLE TRACK PROFILES
SICHTBARE LAUFSCHIENEN - RIELES A LA VISTA - RAILS VISIBLES



MY METALGLAS

Configure your system
Konfigurieren Sie Ihr System
Configura tu sistema
Configurer votre système

Sliding system	V-5603	V-5653	V-5703
Max	120 kg	80 kg	120 kg
Soft-close	70-80-100-120 kg (optional)	70-80-100-120 kg (optional)	70-80-100-120 kg (optional)

	8/10	8.76/10.76/12 12.76/13.52 with-mit-con-avec V-5607		500 min 1000 max
--	------	--	--	---------------------

Ceiling
Decke
A Techo
Plafond

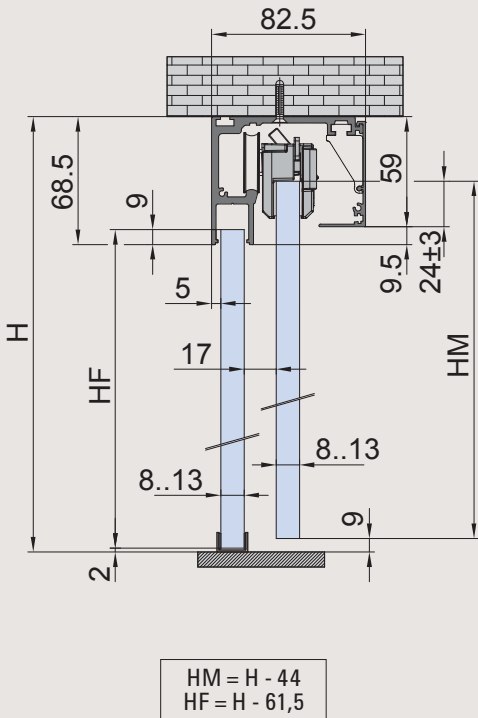

xme576c

Wall
Wand
A Pared
Mur

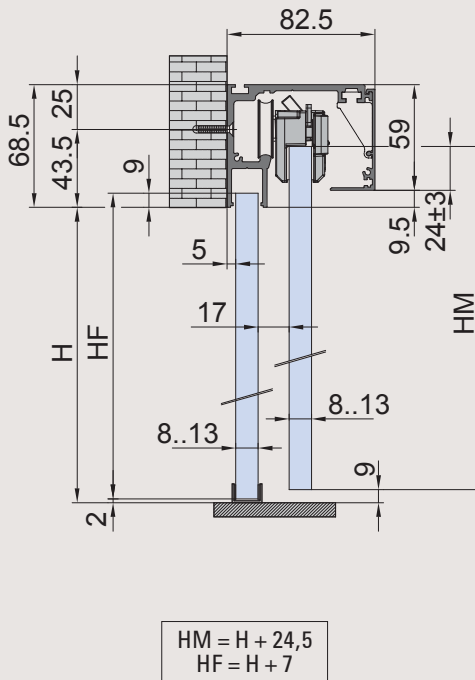

xme576b

Glass preparation
Glasbearbeitung
Procesamiento de vidrio
Traitement du verre

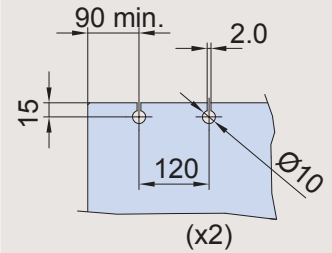

- Holes optional
- Borungen Optional
- Agujeros opcionales
- Trous optionnels

OPTIONAL	
VP-019-MT	VP-018-MT
2	3
1000 mm - 2000 mm - 3000 mm	
<ul style="list-style-type: none"> • Gaskets for fixed glass • <u>Dichtungen für Seitenteil</u> • <u>Juntas para vidrio fijo</u> • <u>Joints pour verre fixe</u> 	
8	10
12	

SET 1

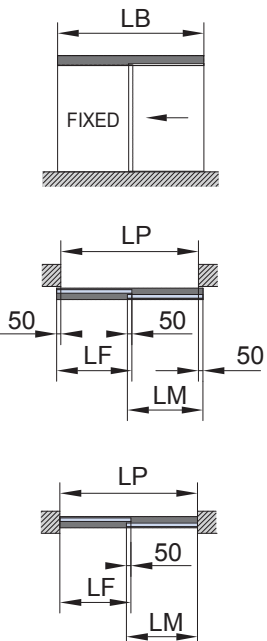

$$LB = LP + 100$$

$$LM/LF = (LP + 150) / 2$$

$$LB = LP$$

$$LM/LF = (LP + 50) / 2$$

SET 2

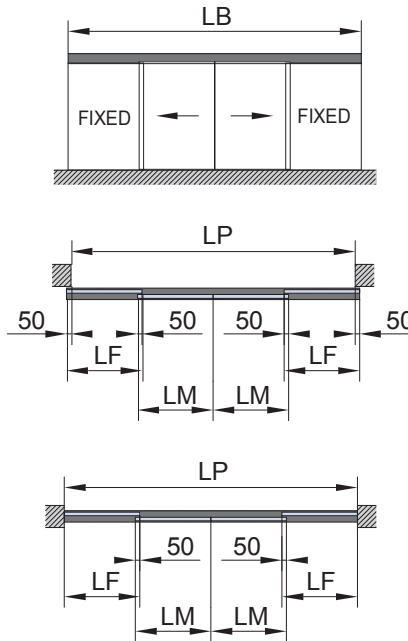

$$LB = LP + 100$$

$$LM/LF = (LP + 200) / 4$$

$$LB = LP$$

$$LM/LF = (LP + 100) / 4$$

ESSENZA - Ri-EVOLUTION

INVISIBLE TRACK PROFILES
UNSIHTBARE LAUFSCHIENEN - RIELES INVISIBLES - RAILS INVISIBLES



MY METALGLAS

Configure your system
Konfigurieren Sie Ihr System
Configura tu sistema
Configurer votre système

Sliding system	V-7600	+ V-7605
Max	120 kg	(optional)
Soft-close	70-80-100-120 kg (optional)	

8/10	8.76/10.76/12 12.76/13.52	500 min 1000 max
with-mit-con-avec V-5607		

Ceiling
Decke
A Techo
Plafond

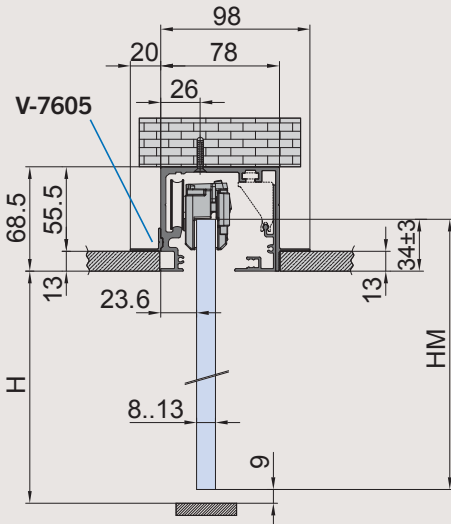

$$HM = H + 25$$

xme576f

Wall
Wand
A Pared
Mur

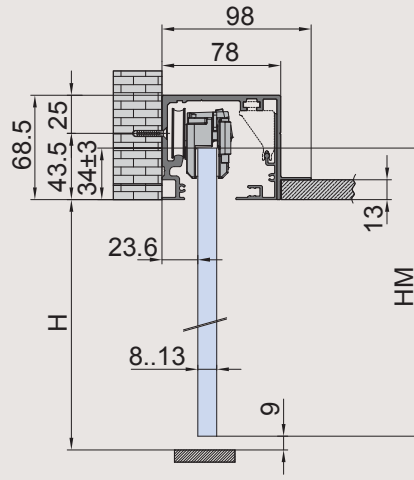

$$HM = H + 25$$

Glass preparation
Glasbearbeitung
Procesamiento de vidrio
Traitement du verre

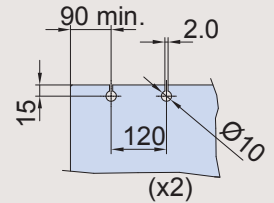

- Holes optional
- Bohrungen Optional
- Agujeros opcionales
- Trous optionnels

SET 1

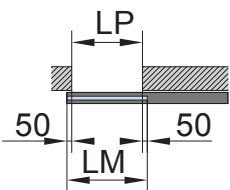
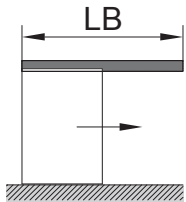

$$LB = LP \times 2 + 150$$

$$LM = LP + 100$$

SET 2

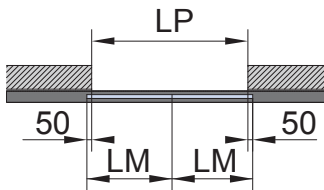
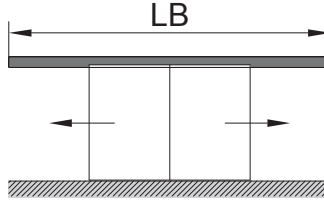

$$LB = LP \times 2 + 100$$

$$LM = (LP + 100) / 2$$

ESSENZA - Ri-EVOLUTION

INVISIBLE TRACK PROFILES
UNSICHTBARE LAUFSCHIENEN - RIELES INVISIBLES - RAILS INVISIBLES



MY METALGLAS

Configure your system
Konfigurieren Sie Ihr System
Configura tu sistema
Configurer votre système

Sliding system	V-7603	+ V-7605
Max	120 kg	(optional)
Soft-close	70-80-100-120 kg (optional)	

8/10	8.76/10.76/12 12.76/13.52	500 min 1000 max
with-mit-con-avec V-5607		

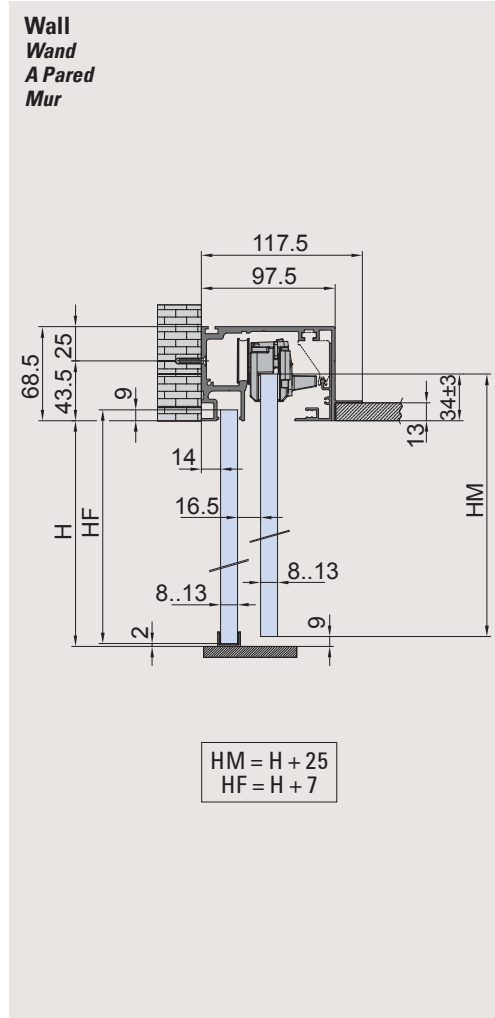
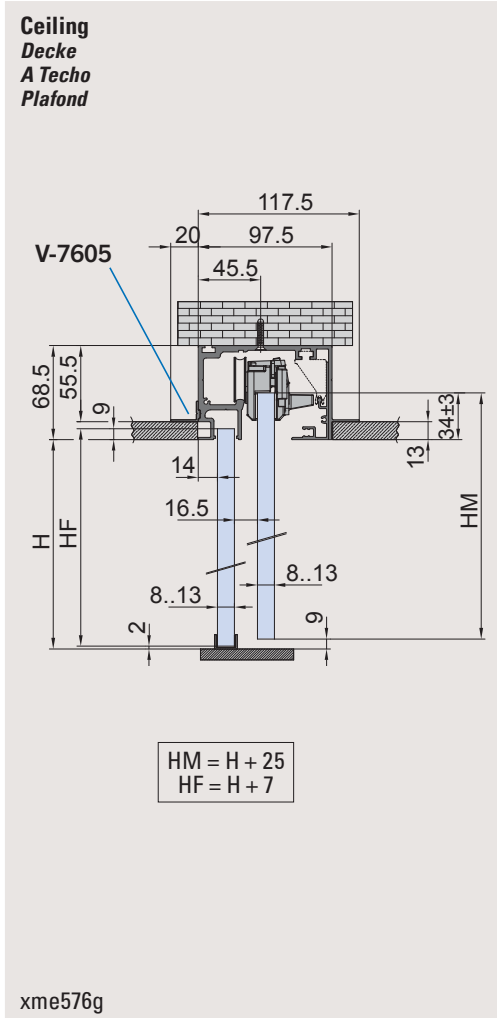

Glass preparation
Glasbearbeitung
Procesamiento de vidrio
Traitement du verre

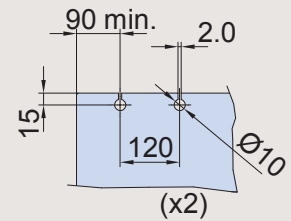

- Holes optional
- **Borungen Optional**
- **Agujeros opcionales**
- **Trous optionnels**

OPTIONAL	
VP-019-MT	VP-018-MT
2	3
1000 mm - 2000 mm - 3000 mm	
<ul style="list-style-type: none"> • Gaskets for fixed glass • <i>Dichtungen für Seitenteil</i> • <i>Juntas para vidrio fijo</i> • <i>Joints pour verre fixe</i> 	
8	10
12	

SET 1

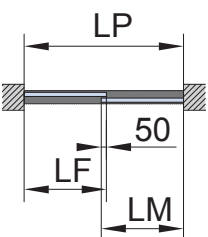
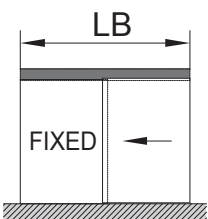

$$LB = LP$$

$$LM / LF = (LP + 50) / 2$$

SET 2

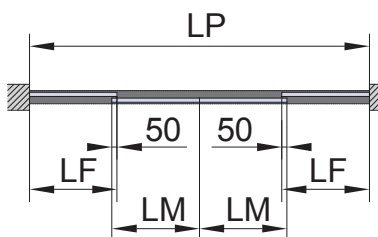
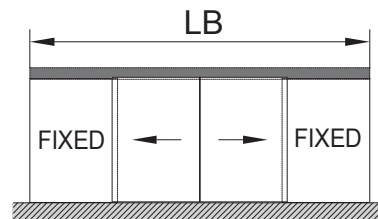

$$LB = LP$$

$$LM / LF = (LP + 100) / 4$$

ESSENZA - Ri-EVOLUTION

INVISIBLE TRACK PROFILES
 UNSICHTBARE LAUFSCHIENEN - RIELES INVISIBLES - RAILS INVISIBLES



MY METALGLAS

Configure your system
 Konfigurieren Sie Ihr System
 Configura tu sistema
 Configurer votre système

Sliding system	V-7650
Max	120 kg
Soft-close	70-80-100-120 kg (optional)

8/10	8.76/10.76/12 12.76/13.52	500 min 1000 max
with-mil-con-avec V-5607		

Wall
 Wand
 A Pared
 Mur

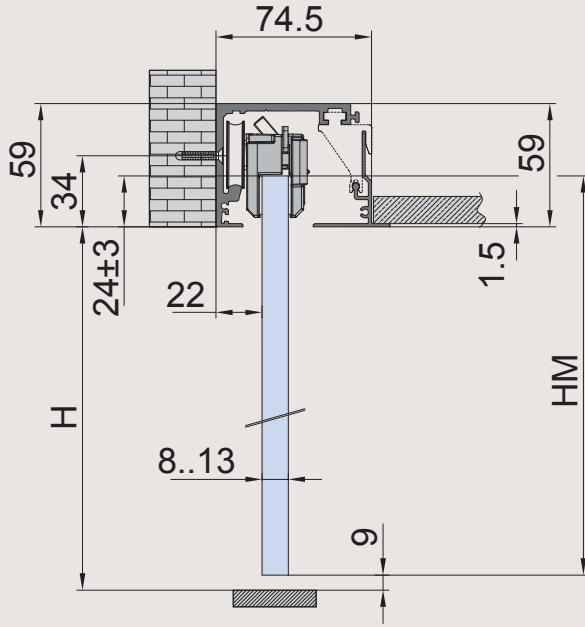

$HM = H + 15$

xme576e

Glass preparation
 Glasbearbeitung
 Procesamiento de vidrio
 Traitement du verre

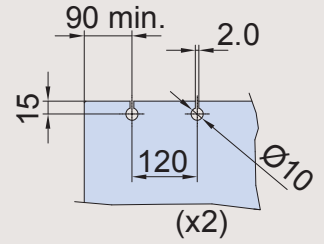

- Holes optional
- Bohrungen Optional
- Agujeros opcionales
- Trous optionnels

SET 1

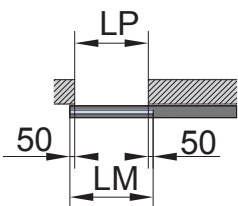
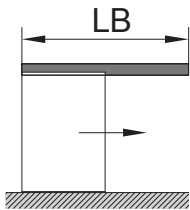

$LB = LP \times 2 + 150$
 $LM = LP + 100$

SET 2

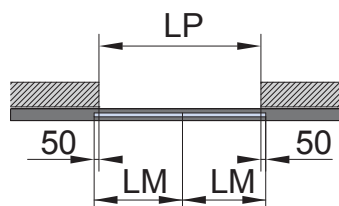
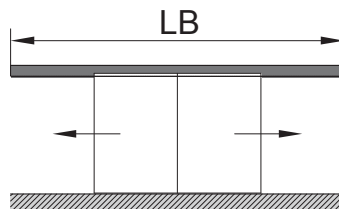

$LB = LP \times 2 + 100$
 $LM = (LP + 100) / 2$

ESSENZA - Ri-EVOLUTION

MY METALGLAS

Configure your system
Konfigurieren Sie Ihr System
Configura tu sistema
Configurer votre système

ACCESSORIES - ZUBEHÖRE - ACCESORIOS - ACCESSOIRES

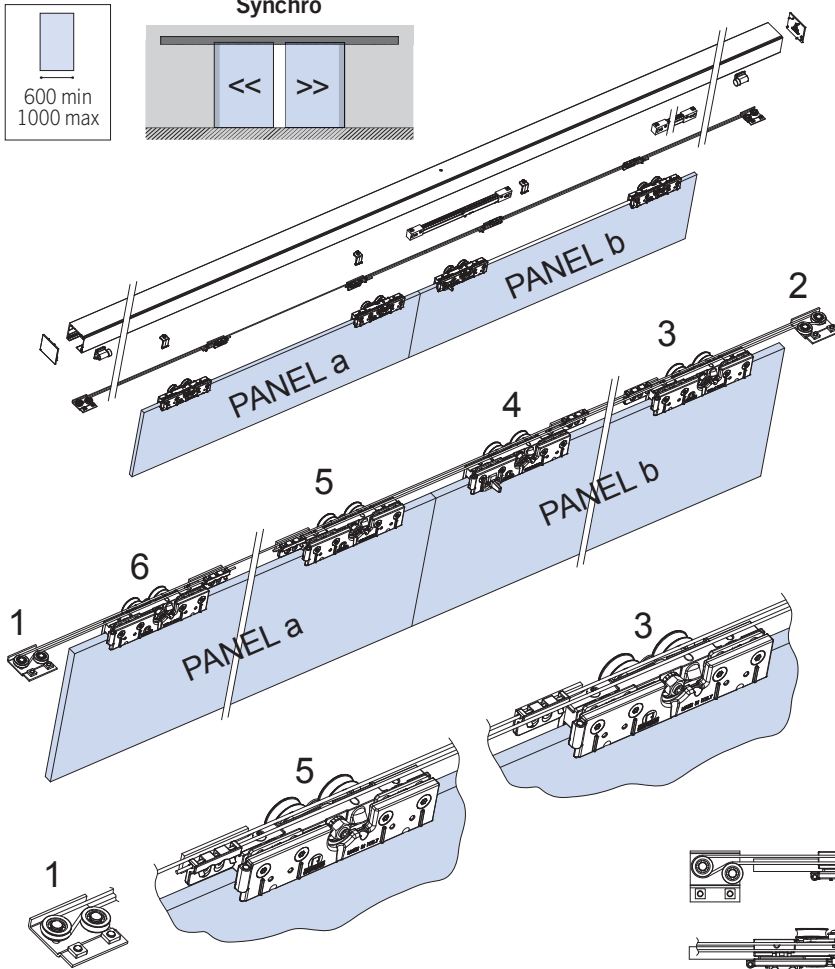
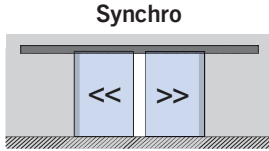
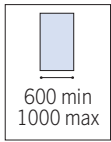

V-5610

- Extra kit for 2 panels synchronously opening. Available for systems Ri-EVOLUTION V-5600 / V-5603
- Set für 2 Synchron öffnende Schiebeteile. Verfügbar für Systeme Ri-EVOLUTION V-5600 / V-5603
- Kit extra para apertura simultánea de 2 puertas. Disponible para sistemas Ri-EVOLUTION V-5600 / V-5603
- Kit supplémentaire pour l'ouverture simultanée de 2 vantaux. Disponible pour les systèmes Ri-EVOLUTION V-5600 / V-5603

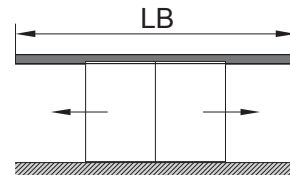

$$LB = LP \times 2 + 180$$

$$LM = (LP + 100) / 2$$

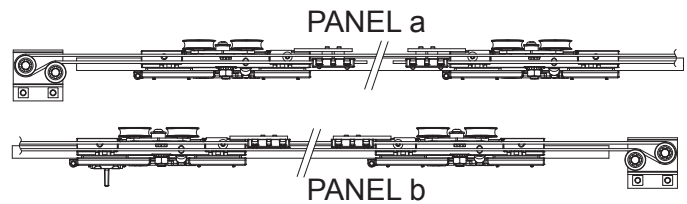
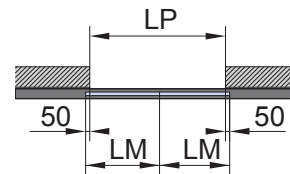

xme576m

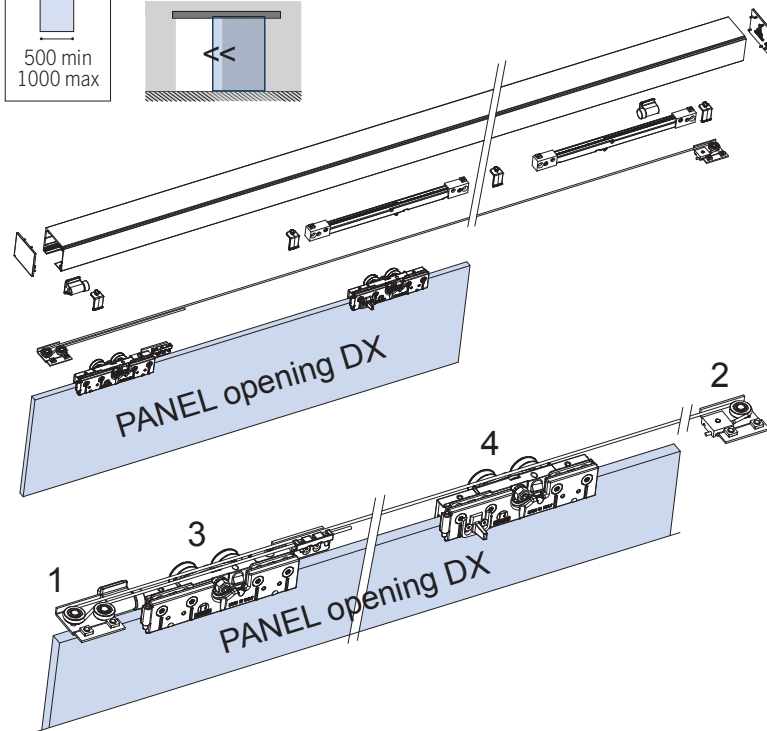
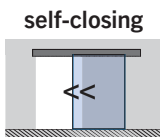
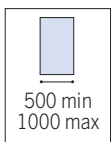

V-5615

- Extra kit for panel self-closing. Mechanism integrated in the track profile requiring no external power supply. Available for systems Ri-EVOLUTION V-5600 / V-5603
- Set für selbstschließende Tür. System im Laufprofil unsichtbar und ohne Strombedarf. Verfügbar für Systeme Ri-EVOLUTION V-5600 / V-5603
- Kit extra para puerta de cierre automático. Mecanismo integrado en pista sin necesidad de energía externa. Disponible para sistema Ri-EVOLUTION V-5600 / V-5603
- Kit supplémentaire pour la fermeture automatique des portes. Mécanisme intégré dans le rail sans besoin d'énergie extérieure. Disponible pour les systèmes Ri-EVOLUTION V-5600 / V-5603

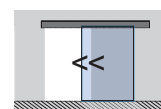

V-5615 DX
Right opening
Öffnung Rechts
Abriendo a la derecha
Ouverture à droite

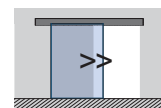

V-5615 SX
Left opening
Öffnung Links
Apertura izquierda
Ouverture à gauche

<< self-closing

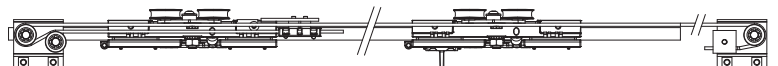

xme576n