

TECHNICAL PAGES

TECHNISCHE SEITEN
PÁGINAS TÉCNICAS
SECTION TECHNIQUE

ACRONYM LEGEND

ERKLÄRUNG DER ABKÜRZUNGEN - LEYENDA - LEGENDE

LP	CLEAR OPENING WIDTH <i>LICHTE DURCHGANGSBREITE</i> <i>ANCHO DE APERTURA LIBRE</i> <i>LARGEUR D'OUVERTURE PASSAGE</i>	LB	RAIL LENGTH <i>LAUFSCHIENENLÄNGE</i> <i>LONGITUD RIEL</i> <i>LONGUEUR RAIL</i>
H / HP	CLEAR OPENING HEIGHT <i>LICHTE DURCHGANGSHÖHE</i> <i>ALTURA DE APERTURA LIBRE</i> <i>HAUTER D'OUVERTURE PASSAGE</i>	LV	GLASS WIDTH <i>GLAS BREITE</i> <i>ANCHO DE VIDRIO</i> <i>LARGEUR DE VERRE</i>
HM / HA	SLIDING GLASS HEIGHT <i>SCHIEBEFLÜGEL HÖHE</i> <i>ALTURA DE PANEL MÓVIL</i> <i>HAUTEUR PANNEAU MOBILE</i>	HV	GLASS HEIGHT <i>GLAS HÖHE</i> <i>ALTURA VIDRIO</i> <i>HAUTEUR DU VERRE</i>
HF	SIDE FIXED GLASS HEIGHT <i>SEITENTEIL HÖHE</i> <i>ALTURA DE PANEL FIJO</i> <i>HAUTEUR PANNEAU FIXE</i>	LF	FIXED GLASS WIDTH <i>FESTGLASBREITE</i> <i>ANCHO DE VIDRIO FIJO</i> <i>LARGEUR DU VERRE FIXE</i>
HFA	VERTICAL PROFILE HEIGHT FIXED PANEL <i>VERTIKALPROFIL HÖHE SEITENTEIL</i> <i>ALTURA DEL PERFIL VERTICAL PANEL FIJO</i> <i>HAUTEUR DU PROFIL VERTICAL PANNEAU FIXE</i>	L TRAVERSO	HORIZONTAL PROFILE LENGTH <i>HORIZONTALPROFIL LÄNGE</i> <i>LONGITUD DEL PERFIL HORIZONTAL</i> <i>LONGUEUR DU PROFIL HORIZONTAL</i>
HA	VERTICAL PROFILE HEIGHT MOVABLE PANEL <i>VERTIKALPROFIL HÖHE SCHIEBE- UND DREHFLÜGEL</i> <i>ALTURA DEL PERFIL VERTICAL PANEL MÓVIL</i> <i>HAUTEUR DU PROFIL VERTICAL PANNEAU MOBILE</i>	HS	FRAME HEIGHT <i>ZARGE HÖHE</i> <i>ALTURA DEL MARCO</i> <i>HAUTEUR DU ENCADREMENT</i>
LM / LA	MOVABLE DOOR WIDTH <i>SCHIEBE- UND DREHFLÜGEL BREITE</i> <i>ANCHO DE PANEL MÓVIL</i> <i>LARGEUR PANNEAU MOBILE</i>	LS	FRAME WIDTH <i>ZARGE BREITE</i> <i>ANCHO DEL MARCO</i> <i>LARGEUR DU ENCADREMENT</i>
LAF	FIXED GLASS WIDTH <i>SEITENTEIL BREITE</i> <i>ANCHO DE PANEL FIJO</i> <i>LARGEUR PANNEAU FIXE</i>	LMP	DOOR MODULE <i>TÜRMODULE</i> <i>MÓDULO DE PUERTA</i> <i>MODULE DE PORTE</i>

DIV-100 DOOR

FRAMED HINGED DOOR WITH HINGES DIV-V742

GERAHMTE DREHTÜR MIT BÄNDER DIV-V742 - PUERTA BATIENTE ENMARCADA CON BISAGRAS DIV-V742 - PORTE À CADRE AVEC PAUMELLES DIV-V742

MY METALGLAS

Configure your panel to calculate the cross profiles
 Konfigurieren Sie Ihre Tür und berechnen Sie automatisch die Querprofile
 die Querprofile
 Compongá su puerta para cuantificar los travesaños por encargo
 Composez votre porte pour quantifier les traverses à commander

Door / Tür / Puerta / Porte DIV-100

Max 

55 kg

With preparation for locks (lock not included)

Mit Vorbereitung für Schlösser (Schloss nicht enthalten)

Preparación para cerraduras (cerradura no incluida)

Avec la preparation pour les serrures (suerre non inclus)

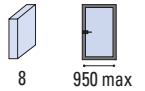

LA/HA based on the door jamb model (from page 40)
 LA/HA bestimmt durch das Zargenmodell (ab Seite 40)
 LA/HA basando en la jamba de la puerta modelo (desde la pag 40)
 LA/HA basé sur le modèle du montant de la porte

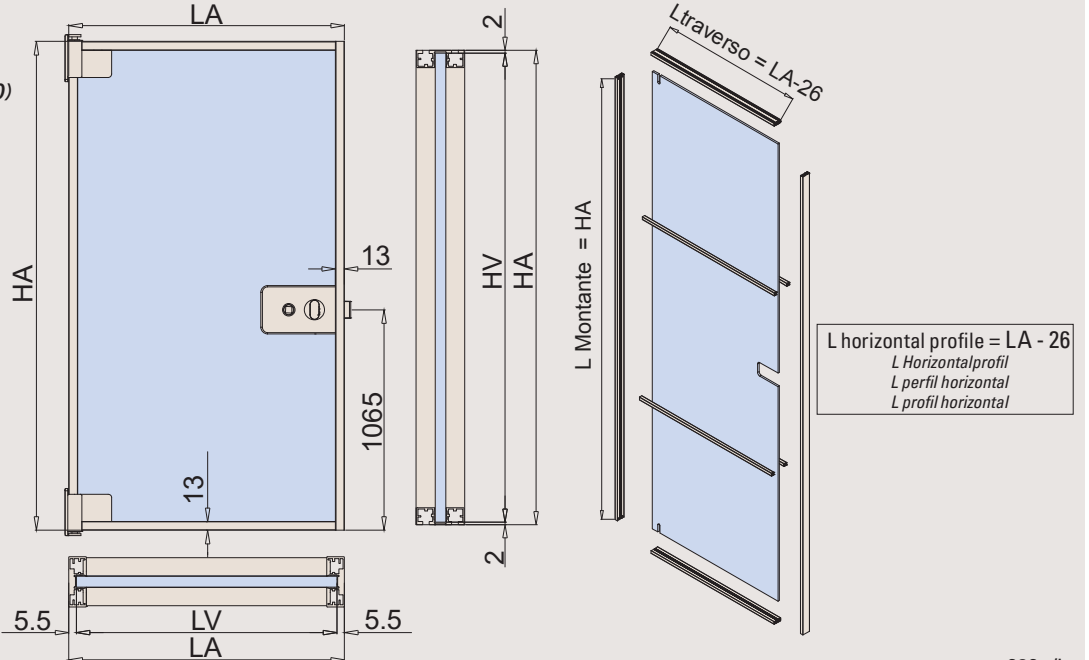

xme636a/h

DIV-100-S2FLG + DIV-100-F2FLG DOUBLE DOOR

FRAMED PANELS FOR DOUBLE DOOR

GERAHMTE FLÜGEL FÜR 2FLG TÜR - PANELES ENMARCADOS PARA PUERTAS DOBLES - PANNEAUX POUR PORTE DOUBLE

Door / Tür / Puerta / Porte DIV-100-S2FLG + DIV-100-F2FLG

Max 

55 kg

With preparation for locks (not included)

Mit Vorbereitung für Schlösser (nicht enthalten)

Preparación para cerraduras (no incluida)

Avec la preparation pour les serrures non inclus

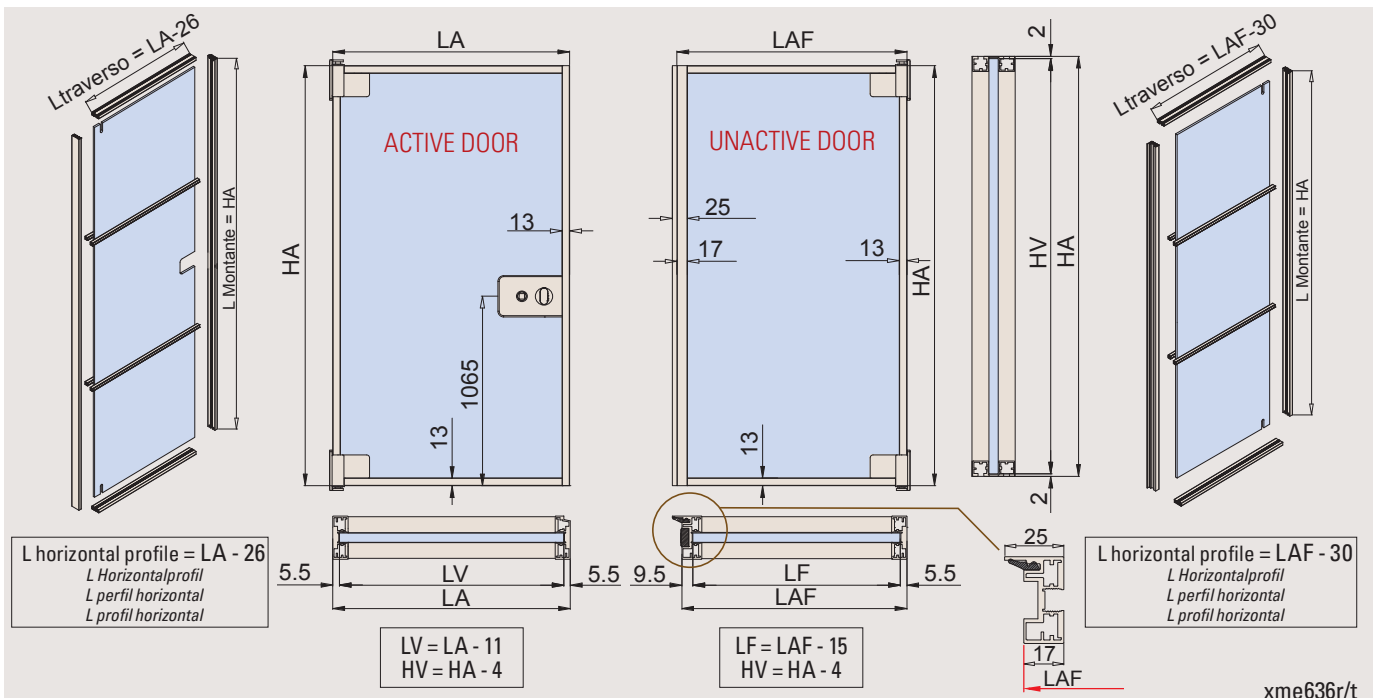
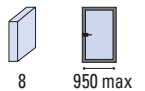

xme636r/t

DIV-100 GLASS PREPARATION

HINGED DOOR / ACTIVE PANEL FOR DOUBLE DOOR

DREHTÜR / GEHFLÜGEL FÜR 2FLG TÜR - PUERTA BATIENTE / PANEL ACTIVO DE DOBLE PUERTA - CADRE AVEC PAUMELLES FONCTIONELLE



Glass preparation / Glasbearbeitung / Procesamiento de vidrio / Traitement du verre

(Also for magnetic locks / Auch für Magnetische Schlösser / También para cerraduras magnéticas / magnéticas / Aussi pour les serrures magnétiques)

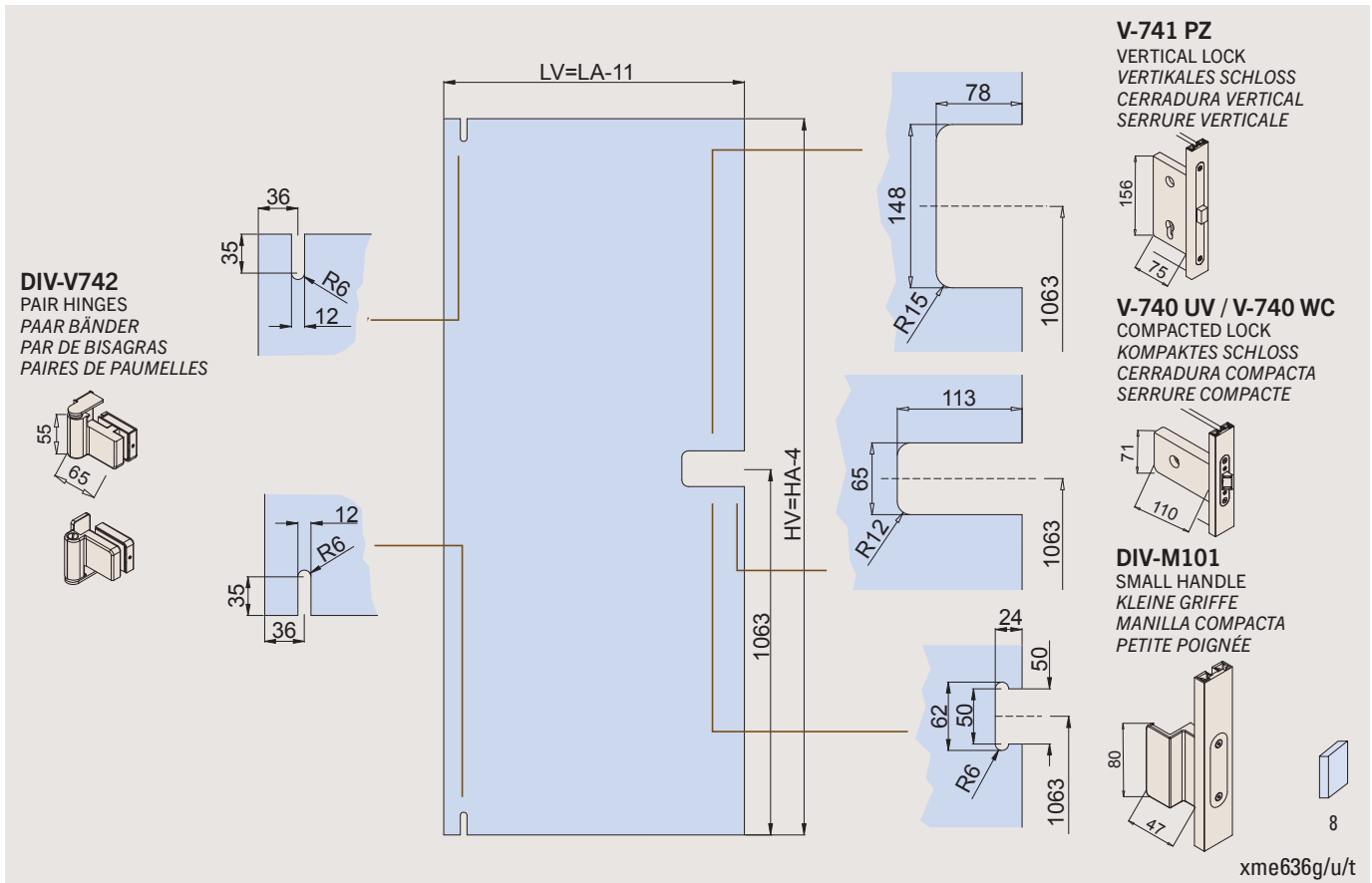

DIV-100-F2FLG GLASS PREPARATION

UNACTIVE PANEL FOR DOUBLE DOOR

STANDFLÜGEL FÜR 2FLG TÜR - PANEL INACTIVO DE PUERTAS DOBLES - PANNEAU INACTIVE POUR PORTE DOUBLE

Glass preparation / Glasbearbeitung / Procesamiento de vidrio / Traitement du verre

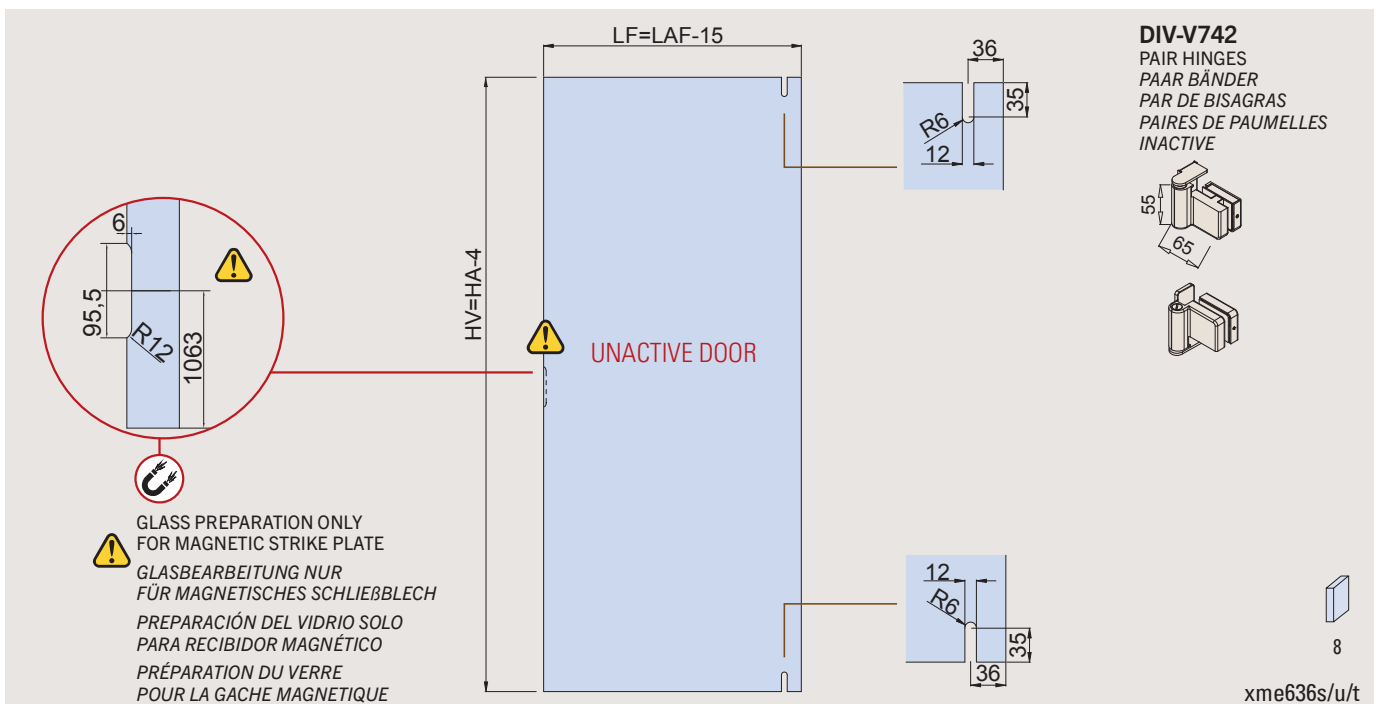

⚠️ GLASS PREPARATION ONLY FOR MAGNETIC STRIKE PLATE
GLASBEARBEITUNG NUR FÜR MAGNETISCHES SCHLIEBBLECH
PREPARACIÓN DEL VIDRIO SOLO PARA RECIBIDOR MAGNÉTICO
PRÉPARATION DU VERRE POUR LA GACHE MAGNETIQUE

DIV-030

COMPLETE SET P-030 DOOR JAMB + DIV-100 HINGED DOOR - KOMPLETT-SET P-030 ZARGE + DIV-100 DREHTÜR - SET COMPLETO DE JAMBA P-030 + DIV-100 PUERTA BATIENTE - KIT COMPLET P-030 MONTANT DE PORTE + DIV-100 CADRE AVEC PAUMELLES



MY METALGLAS

Configure your panel to calculate the cross profiles
Konfigurieren Sie Ihre Tür und berechnen Sie automatisch die Querprofile
Componga su puerta para cuantificar los travesaños por encargo
Composez votre porte pour quantifier les traverses à commander

SET = P-030

Door jamb cut to size, profiles preparation included
Zarge nach Maß geschnitten, Profile bearbeitet
Jambas de puerta cortada a medida, preparación de perfiles incluida
Montant de porte coupé sur mesure préparation des profils inclus

+ DIV-100

Framed panel with hinges
Gerahmte Tür mit Bänder
Panel enmarcado con bisagras
Cadre avec paumelles



Lock and handle
Schloss und Griff
Cerradura y manilla
Serrure et poignée

+ P-033 (optional)

Wall profile for adjustment
Wandprofil für Verstellung
Perfil a muro para regulación
Profil pour ajustement mural

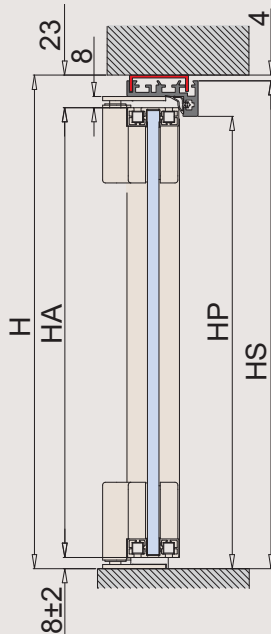
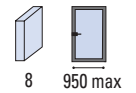

Optional wall profile for adjustment P-033
Wandprofil für Verstellung P-033
Perfil a muro para regulación P-033 opcional
Profil d'alignement mural P-033 en option

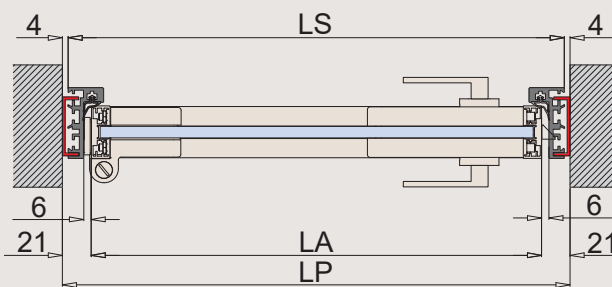
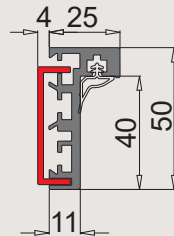

With / Mit / Con / Avec P-033

LA = LP - 42
HA = H - 31
LS = LP - 8
HS = H - 4

Without / Ohne / Sin / Sans P-033

LA = LP - 34
HA = H - 27
LS = LP
HS = H

Glass / Glas / Vidrio / Verre

LV = LA - 11
HV = HA - 4

xme636f

DIV-040

COMPLETE SET P-040 DOOR JAMB + DIV-100 HINGED DOOR
KOMPLETT-SET P-040 ZARGE + DIV-100 DREHTÜR - SET COMPLETO DE JAMBA P-040 + DIV-100 PUERTA BATIENTE - KIT COMPLET P-030 MONTANT DE PORTE + DIV-100 CADRE AVEC PAUMELLES

SET = P-040

Door jamb cut to size, profiles preparation included
Zarge nach Maß geschnitten, Profile bearbeitet
Jambas de puerta cortada a medida, preparación de perfiles incluida
Montant de porte coupé sur mesure, preparation des profils inclus

+ DIV-100

Framed panel with hinges
Gerahmte Tür mit Bänder
Panel enmarcado con bisagras
Cadre avec paumelles



Lock and handle
Schloss und Griff
Cerradura y manilla
Serrure et poignée

+ P-033 (optional)

Wall profile for adjustment
Wandprofil für Verstellung
Perfil a muro para regulación
Profil pour ajustement mural

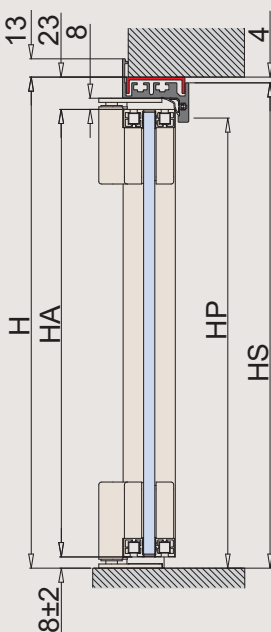
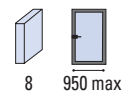

Optional wall profile for adjustment P-033
Wandprofil für Verstellung P-033
Perfil a muro para regulación P-033 opcional
Profil d'alignement mural P-033 en option

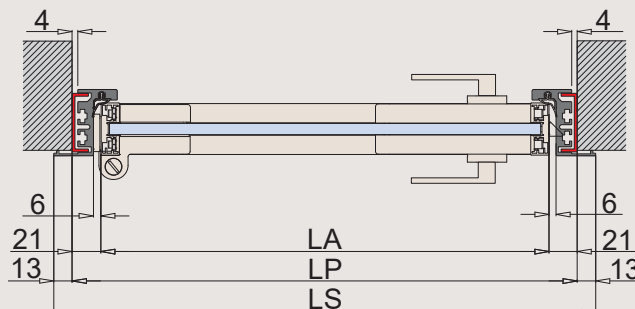
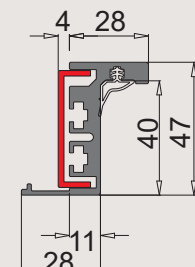

With / Mit / Con / Avec P-033

LA = LP - 42
HA = H - 31
LS = LP + 26
HS = H + 13

Without / Ohne / Sin / Sans P-033

LA = LP - 34
HA = H - 27
LS = LP + 34
HS = H + 17

Glass / Glas / Vidrio / Verre

LV = LA - 11
HV = HA - 4

xme636e

DIV-300

COMPLETE SET TP-300 DOOR JAMB + DIV-100 HINGED DOOR - KOMPLETT-SET TP-300 ZARGE + DIV-100 DREHTÜR - SET COMPLETO DE JAMBA TP-300 + DIV-100 PUERTA BATIENTE - KIT COMPLET TP-300 MONTANT DE PORTE + DIV-100 CADRE AVEC PAUMELLES

MY METALGLAS

Configure your panel to calculate the cross profiles
Konfigurieren Sie Ihre Tür und berechnen Sie automatisch die Querprofile
Componga su puerta para cuantificar los travesaños por encargo
Composez votre porte pour quantifier les traverses à commander

SET = TP-300

Door jamb cut to size, profiles preparation included
Zarge nach Maß geschnitten, Profile bearbeitet
Jambas de puerta cortada a medida, preparación de perfiles incluida
Montant de porte coupé sur mesure, préparation des profils inclus

+ DIV-100

Framed panel with hinges
Gerahmte Tür mit Bänder
Panel enmarcado con bisagras
Cadre avec paumelles

+

Lock and handle
Schloss und Griff
Cerradura y manilla
Serrure et poignée

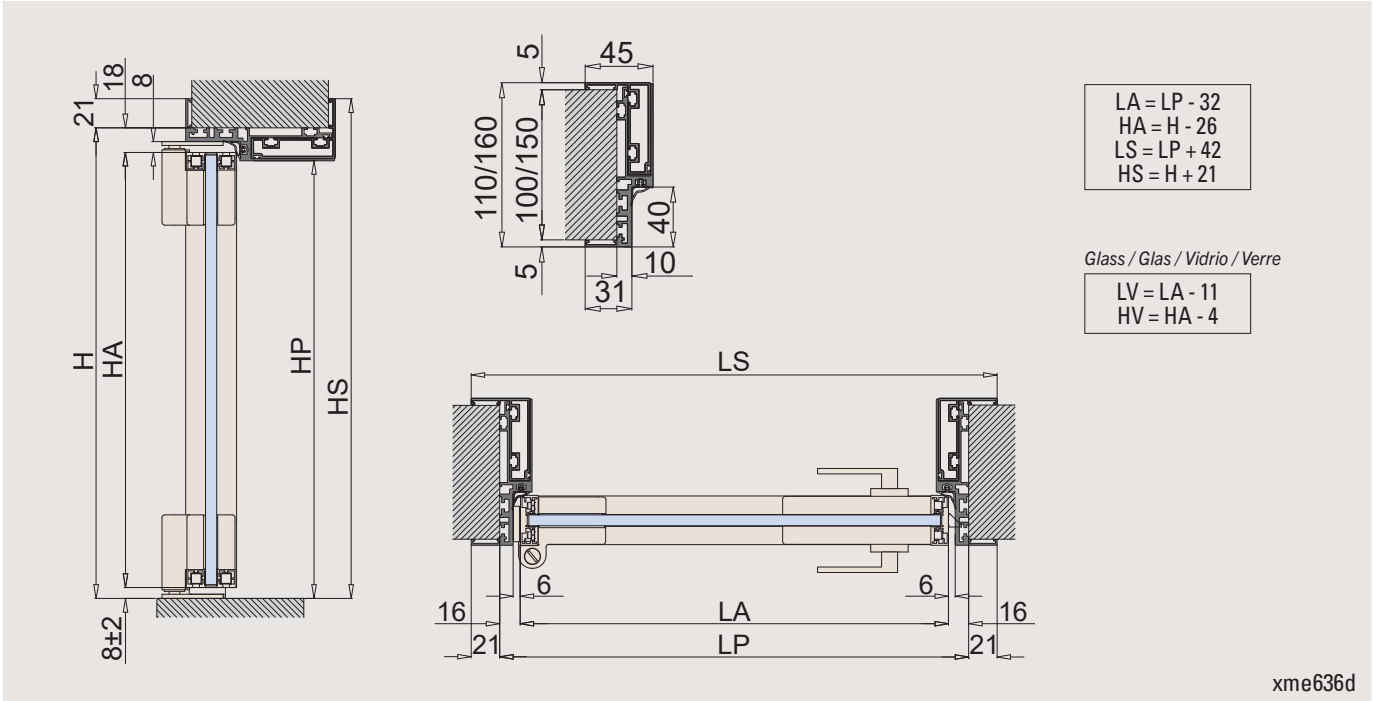
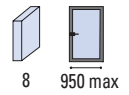

DIV-250

COMPLETE SET TP-250 DOOR JAMB + DIV-100 HINGED DOOR
KOMPLETT-SET TP-250 ZARGE + DIV-100 DREHTÜR - SET COMPLETO DE JAMBA TP-250 + DIV-100 PUERTA BATIENTE - KIT COMPLET TP-250 MONTANT DE PORTE + DIV-100 CADRE AVEC PAUMELLES

SET = TP-250

Door jamb cut to size, profiles preparation included
Zarge nach Maß geschnitten, Profile bearbeitet
Jambas de puerta cortada a medida, preparación de perfiles incluida
Montant de porte coupé sur mesure, préparation des profils inclus

+ DIV-100

Framed panel with hinges
Gerahmte Tür mit Bänder
Panel enmarcado con bisagras
Cadre avec paumelles

+

Lock and handle
Schloss und Griff
Cerradura y manilla
Serrure et poignée

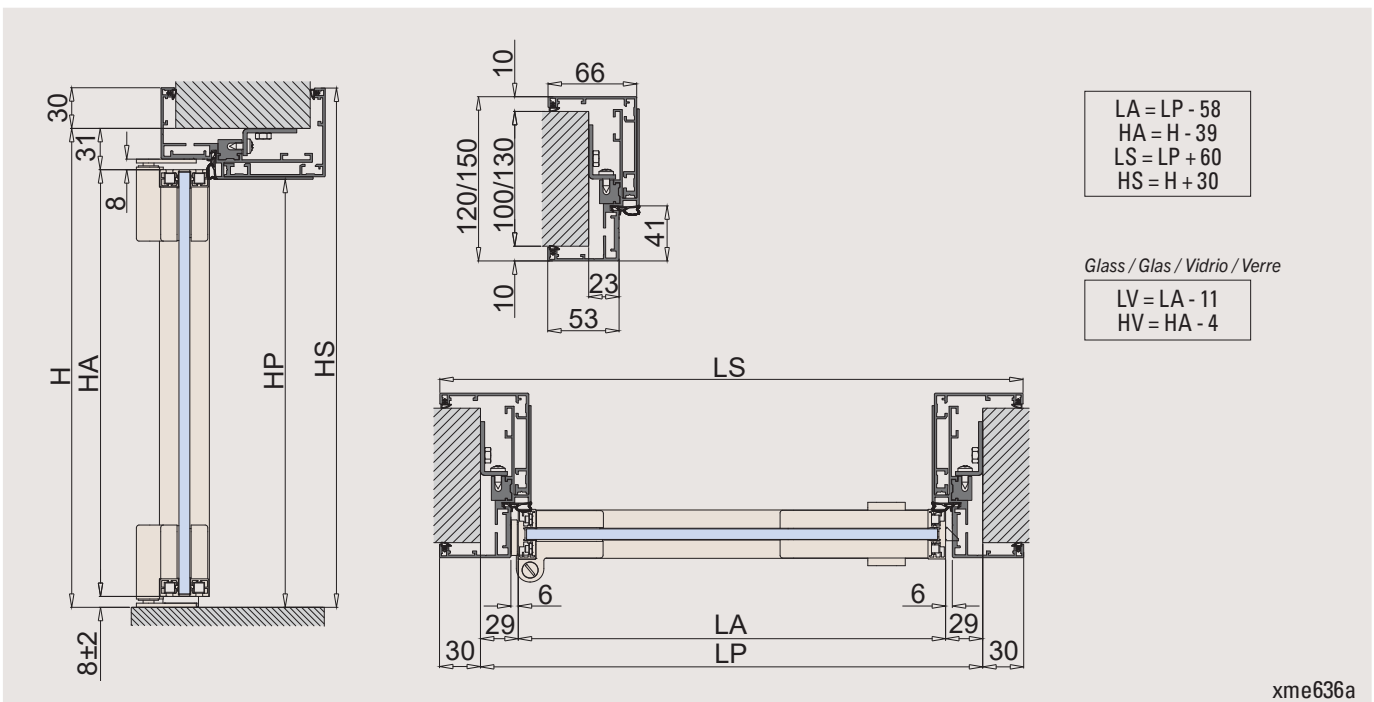
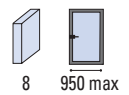

DIV-201

COMPLETE SET TP-201 DOOR JAMB + DIV-100 HINGED DOOR - KOMPLETT-SET TP-201 ZARGE + DIV-100 DREHTÜR - SET COMPLETO DE JAMBA TP-201 + DIV-100 PUERTA BATIENTE - KIT COMPLET TP-201 MONTANT DE PORTE + DIV-100 CADRE AVEC PAUMELLES



MY METALGLAS

Configure your panel to calculate the cross profiles
Konfigurieren Sie Ihre Tür und berechnen Sie automatisch die Querprofile
Componga su puerta para cuantificar los travesaños por encargo
Composez votre porte pour quantifier les traverses à commander

SET = TP-201

Door jamb cut to size, profiles preparation included
Zarge nach Maß geschnitten, Profile bearbeitet
Jambas de puerta cortada a medida, preparación de perfiles incluida
Montant de porte coupé sur mesure, préparation des profils inclus

+ DIV-100

Framed panel with hinges
Gerahmte Tür mit Bänder
Panel enmarcado con bisagras
Cadre avec paumelles

+

Lock and handle
Schloss und Griff
Cerradura y manilla
Serrure et poignée

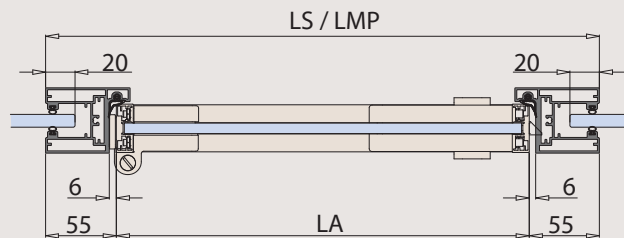
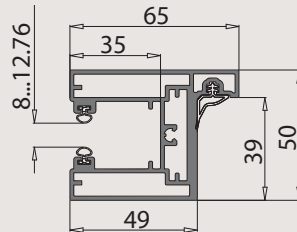
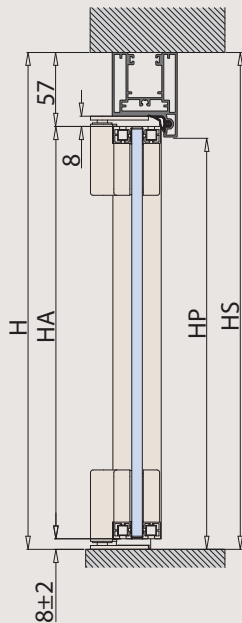
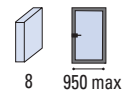

$$\begin{aligned} LA &= LS - 110 \\ HA &= H - 65 \\ LS &= LMP = LA + 108 \\ HS &= H \end{aligned}$$

Glass / Glas / Vidrio / Verre

$$\begin{aligned} LV &= LA - 11 \\ HV &= HA - 4 \end{aligned}$$

8 (Door / Tür / Puerta / Porte)

10 (Fixed glass / Festverglasung / Vidrio fijo / Verre fixe)

xme636b

DIV-201-2FLG

COMPLETE SET TP-201 DOOR JAMB + DIV-100 DOUBLE DOOR

KOMPLETT-SET TP-201 ZARGE + DIV-100 ZWEIFLÜGELIGE TÜR - SET COMPLETO DE JAMBA TP-201 + DIV-100 PUERTA BATIENTE DOBLE - KIT COMPLET MONTANT DE PORTE TP-101 + DIV-100 DOUBLE PORTE

SET = TP-201

Door jamb cut to size, profiles preparation included
Zarge nach Maß geschnitten, Profile bearbeitet
Jambas de puerta cortada a medida, preparación de perfiles incluida
Montant de porte coupé sur mesure, préparation des profils inclus

+ DIV-100-S2FLG + DIV-100-F2FLG

Framed panels with hinges
Gerahmte Türen mit Bänder
Paneles enmarcados con bisagras
Cadre pour double porte

+

Lock and handle
Schloss und Griff
Cerradura y manilla
Serrure et poignée

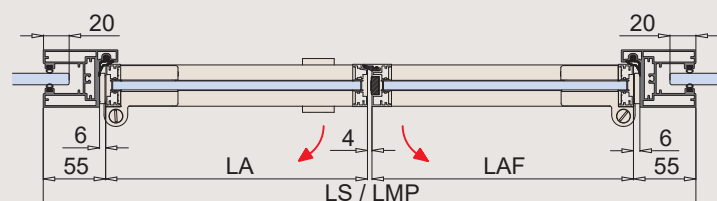
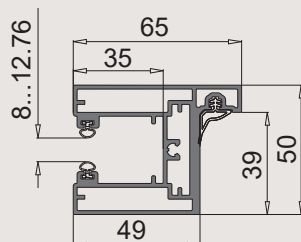
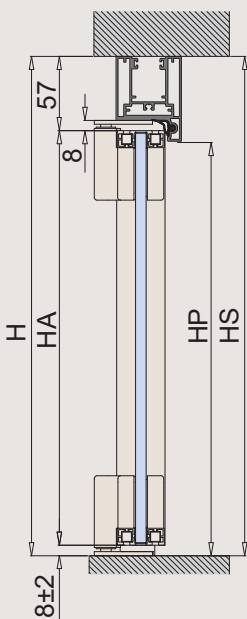
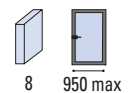

$$\begin{aligned} LA &= LAF = (LS - 114) / 2 \\ HA &= H - 65 \\ LS &= LMP = LA + LAF + 112 \\ HS &= H \end{aligned}$$

Active door glass
Gehflügel Glas
Puerta activa
Porte battante

$$\begin{aligned} LV &= LA - 11 \\ HV &= HA - 4 \end{aligned}$$

Inactive door glass
Standflügel Glas
Puerta inactiva
Porte inactive

$$\begin{aligned} LF &= LAF - 15 \\ HV &= HA - 4 \end{aligned}$$

xme636n

DIV-030-2FLG

COMPLETE SET P-030 DOOR JAMB + DIV-100 DOUBLE DOOR - KOMPLETT-SET P-030 ZARGE + DIV-100 ZWEIFLÜGELIGE TÜR - SET COMPLETO DE JAMBA TP-300 + DIV-100 PUERTA BATIENDE - KIT COMPLET DIV-030 MONTANT DE PORTE PLUS DIV-100 DOUBLE PORTE

MY METALGLAS

Configure your panel to calculate the cross profiles
Konfigurieren Sie Ihre Tür und berechnen Sie automatisch die Querprofile
Componga su puerta para cuantificar los travesaños por encargo
Composez votre porte pour quantifier les traverses à commander

SET = P-030

Door jamb cut to size, profiles preparation included
Zarge nach Maß geschnitten, Profile bearbeitet
Jambas de puerta cortada a medida, preparación de perfiles incluida
Montant de porte coupé sur mesure préparation des profils inclus

+ DIV-100-S2FLG + DIV-100-F2FLG

Framed panels with hinges
Gerahmte Türen mit Bänder
Paneles enmarcados con bisagras
Cadre pour double porte

Lock and handle
Schloss und Griff
Cerradura y manilla
Serrure et poignée

+ P-033 (optional)

Wall profile for adjustment
Wandprofil für Verstellung
Perfil a muro para regulación
Profil mural d'ajustement

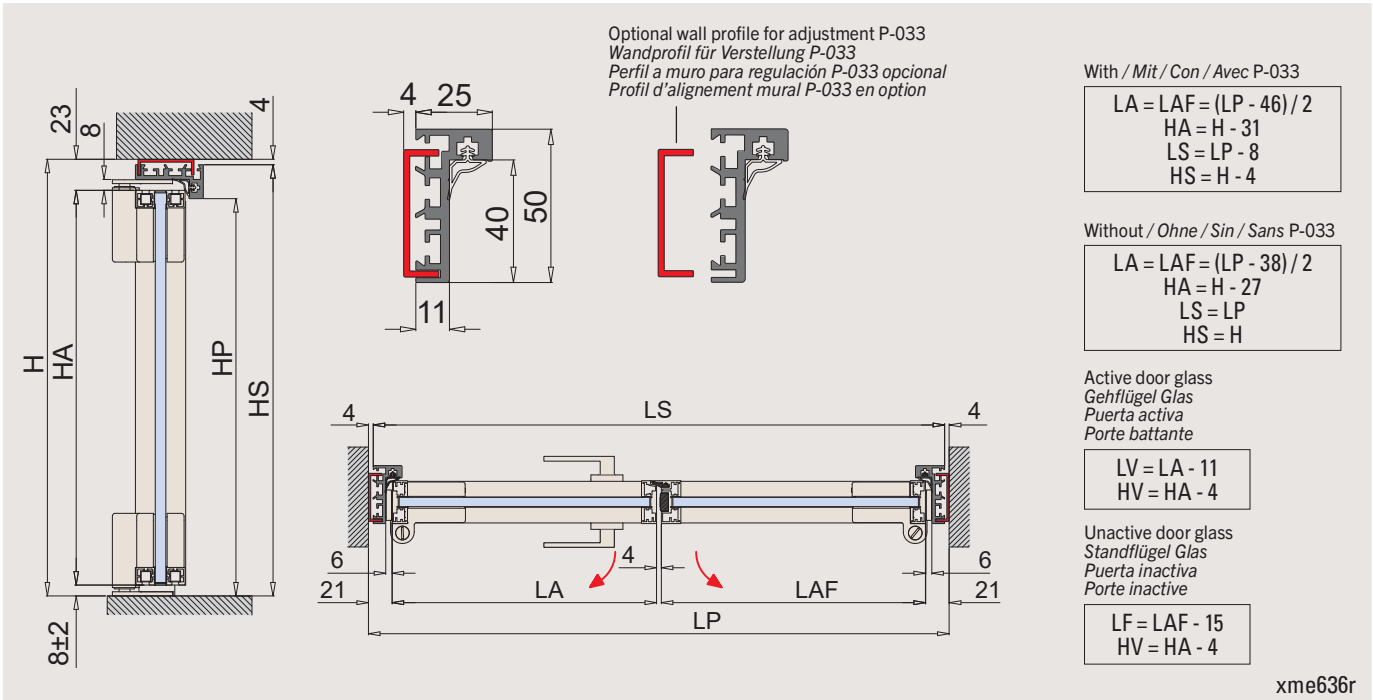
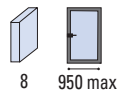

DIV-040-2FLG

COMPLETE SET P-040 DOOR JAMB + DIV-100 DOUBLE DOOR

KOMPLETT-SET P-040 ZARGE + DIV-100 ZWEIFLÜGELIGE TÜR - SET COMPLETO DE JAMBA P-040 + DIV-100 PUERTA BATIENDE DOBLE - KIT COMPLET MONTANT DE PORTE P-040 + DIV-100 DOUBLE PORTE

SET = P-040

Door jamb cut to size, profiles preparation included
Zarge nach Maß geschnitten, Profile bearbeitet
Jambas de puerta cortada a medida, preparación de perfiles incluida
Montant de porte coupé sur mesure, préparation des profils inclus

+ DIV-100-S2FLG + DIV-100-F2FLG

Framed panels with hinges
Gerahmte Türen mit Bänder
Paneles enmarcados con bisagras
Cadre pour double porte

Lock and handle
Schloss und Griff
Cerradura y manilla
Serrure et poignée

+ P-033 (optional)

Wall profile for adjustment
Wandprofil für Verstellung
Perfil a muro para regulación
Profil d'ajustement mural

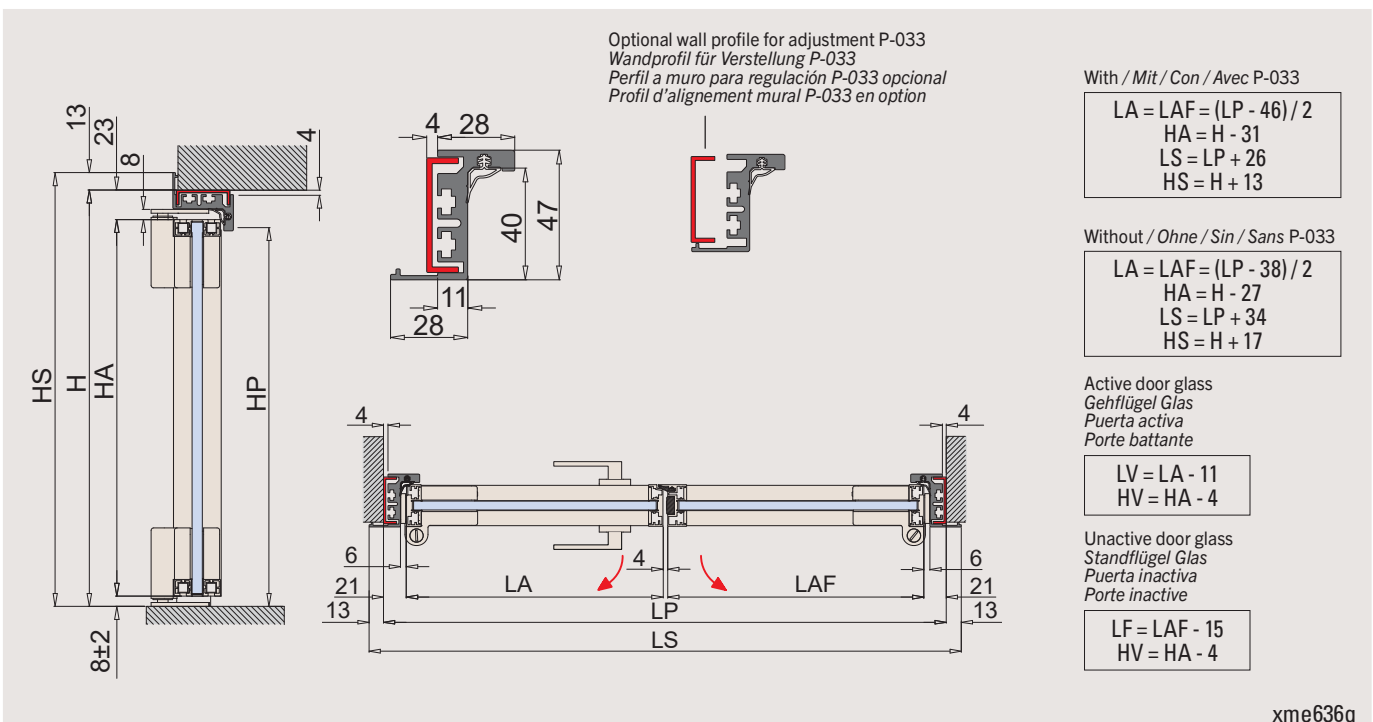
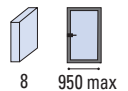

DIV-300-2FLG

COMPLETE SET TP-300 DOOR JAMB + DIV-100 DOUBLE DOOR - KOMPLETT-SET TP-300 ZARGE + DIV-100 ZWEIFLÜGELIGE TÜR - SET COMPLETO DE JAMBA TP-300 + DIV-100 PUERTA BATIENTE DOBLE - KIT COMPLET MONTANT DE PORTE TP-300 + DIV-100 DOUBLE PORTESPORTE

MY METALGLAS

Configure your panel to calculate the cross profiles
Konfigurieren Sie Ihre Tür und berechnen Sie automatisch die Querprofile
Componga su puerta para cuantificar los travesaños por encargo
Composez votre porte pour quantifier les traverses à commander

SET = TP-300

Door jamb cut to size, profiles preparation included
Zarge nach Maß geschnitten, Profile bearbeitet
Jambas de puerta cortada a medida, preparación de perfiles incluida
Montant de porte coupé sur mesure, préparation des profils inclus

+ DIV-100-S2FLG + DIV-100-F2FLG

Framed panels with hinges
Gerahmte Türen mit Bänder
Paneles enmarcados con bisagras
Cadre pour double porte

+ Lock and handle
Schloss und Griff
Cerradura y manilla
Serrure et poignée

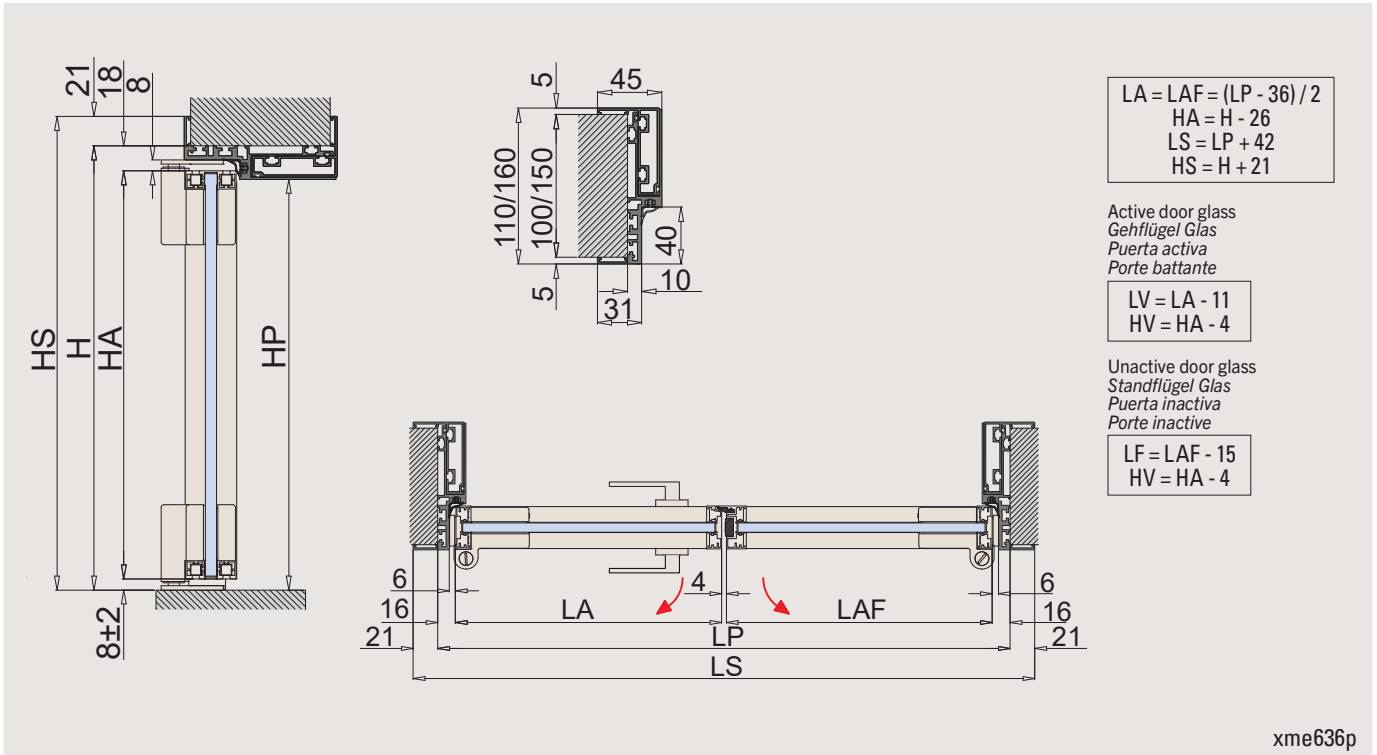
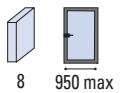

DIV-250-2FLG

COMPLETE SET TP-250 DOOR JAMB + DIV-100 DOUBLE DOOR
KOMPLETT-SET TP-250 ZARGE + DIV-100 ZWEIFLÜGELIGE TÜR - SET COMPLETO DE JAMBA TP-250 + DIV-100 PUERTA BATIENTE DOBLE - KIT COMPLET MONTANT DE PORTE TP-250 + DIV-100 DOUBLE PORTE

SET = TP-250

Door jamb cut to size, profiles preparation included
Zarge nach Maß geschnitten, Profile bearbeitet
Jambas de puerta cortada a medida, preparación de perfiles incluida
Montant de porte coupé sur mesure, préparation des profils inclus

+ DIV-100-S2FLG + DIV-100-F2FLG

Framed panels with hinges
Gerahmte Türen mit Bänder
Paneles enmarcados con bisagras
Cadre pour double porte

+ Lock and handle
Schloss und Griff
Cerradura y manilla
Serrure et poignée

