

# TECHNICAL PAGES

TECHNISCHE SEITEN  
PÁGINAS TÉCNICAS  
SECTION TECHNIQUE

## ACRONYM LEGEND

ERKLÄRUNG DER ABKÜRZUNGEN - LEYENDA - LEGENDE

<b>LP</b>	CLEAR OPENING WIDTH <i>LICHTE DURCHGANGSBREITE ANCHO DE APERTURA LIBRE LARGEUR D'OUVERTURE PASSAGE</i>	<b>LB</b>	RAIL LENGTH <i>LAUFSCHIENENLÄNGE LONGITUD RIEL LONGUEUR RAIL</i>
<b>H / HP</b>	CLEAR OPENING HEIGHT <i>LICHTE DURCHGANGSHÖHE ALTURA DE APERTURA LIBRE HAUTER D'OUVERTURE PASSAGE</i>	<b>LV</b>	GLASS WIDTH <i>GLAS BREITE ANCHO DE VIDRIO LARGEUR DE VERRE</i>
<b>HM / HA</b>	SLIDING GLASS HEIGHT <i>SCHIEBEFLÜGEL HÖHE ALTURA DE PANEL MÓVIL HAUTEUR PANNEAU MOBILE</i>	<b>HV</b>	GLASS HEIGHT <i>GLAS HÖHE ALTURA VIDRIO HAUTEUR DU VERRE</i>
<b>HF</b>	SIDE FIXED GLASS HEIGHT <i>SEITENTEIL HÖHE ALTURA DE PANEL FIJO HAUTEUR PANNEAU FIXE</i>	<b>LF</b>	FIXED GLASS WIDTH <i>FESTGLASBREITE ANCHO DE VIDRIO FIJO LARGEUR DU VERRE FIXE</i>
<b>HFA</b>	VERTICAL PROFILE HEIGHT FIXED PANEL <i>VERTIKALPROFIL HÖHE SEITENTEIL ALTURA DEL PERFIL VERTICAL PANEL FIJO HAUTEUR DU PROFIL VERTICAL PANNEAU FIXE</i>	<b>L TRAVERSO</b>	HORIZONTAL PROFILE LENGTH <i>HORIZONTALPROFIL LÄNGE LONGITUD DEL PERFIL HORIZONTAL LONGUEUR DU PROFIL HORIZONTAL</i>
<b>HA</b>	VERTICAL PROFILE HEIGHT MOVABLE PANEL <i>VERTIKALPROFIL HÖHE SCHIEBE- UND DREHFLÜGEL ALTURA DEL PERFIL VERTICAL PANEL MÓVIL HAUTEUR DU PROFIL VERTICAL PANNEAU MOBILE</i>	<b>HS</b>	FRAME HEIGHT <i>ZARGE HÖHE ALTURA DEL MARCO HAUTEUR DU ENCADREMENT</i>
<b>LM / LA</b>	MOVABLE DOOR WIDTH <i>SCHIEBE- UND DREHFLÜGEL BREITE ANCHO DE PANEL MÓVIL LARGEUR PANNEAU MOBILE</i>	<b>LS</b>	FRAME WIDTH <i>ZARGE BREITE ANCHO DEL MARCO LARGEUR DU ENCADREMENT</i>
<b>LAF</b>	FIXED GLASS WIDTH <i>SEITENTEIL BREITE ANCHO DE PANEL FIJO LARGEUR PANNEAU FIXE</i>	<b>LMP</b>	DOOR MODULE <i>TÜRMODULE MÓDULO DE PUERTA MODULE DE PORTE</i>

# WALL-D1002FL

COMPLETE SET P-030 DOOR JAMB WITH P-088 + DIV-100 HINGED DOUBLE DOOR + CLIP-ON PROFILE DIV-058 - KOMPLETT-SET P-030 ZARGE MIT P-088 + DIV-100 2FLG DREHTÜR + KLIPSPROFIL DIV-058 - SET COMPLETO DE JAMBA P-030 CON P-088 + DIV-100 PUERTA BATIENTE DOBLE + PERFIL DE CLIP DIV-058 - KIT COMPLET MONTANT DE PORTE P-030 + P-088 PROFIL CLIPSABLE PANNEAU FIXE + DIV-100 DOUBLE PORTE + PROFIL CLIPSABLE DIV-058

<b>SET =</b>	<b>P-030</b>	<b>+</b>	<b>P-088</b>	<b>+</b>	<b>DIV-100-S2FLG + DIV-100-F2FLG</b>	<b>+</b>	<b>DIV-058</b>	<b>+</b>	<b>DIV-208 (optional)</b>	<b>+</b>	<b>DIV-204 (optional)</b>
	Door jamb Zarge Jamba de puerta Montant de porte		Pair clip-on profiles for fixed panel Paar Klipsprofile für Festteil Par de junquillos para panel fijo Profil Clipsable pour panneau fixe		Framed panels for double door Gerahmte Flügel für 2flg Tür Paneles enmarcados con bisagras Cadre pour double porte		Clip-on profile Klipsprofil Perfil a clip Profil clipsable		H profile H Profil Perfil "H" Profil en H		Cross profile Querprofil Travesaño Traverse

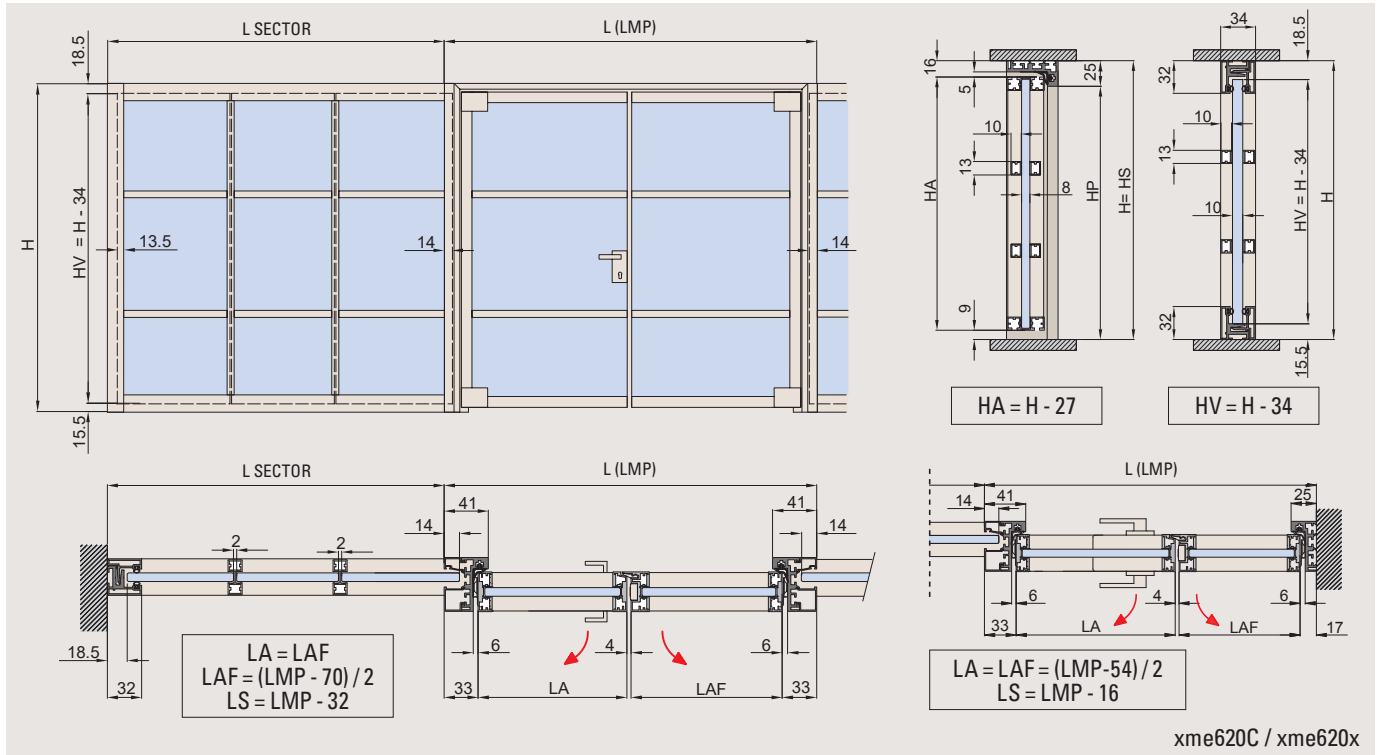

# WALL-DIV100

COMPLETE SET WITH CLIP-ON PROFILE, DOOR JAMB AND FRAMED HINGED DOOR

KOMPLETTSET MIT KLIPSPROFIL, ZARGE UND GERÄHMTE DREHTÜR - SET COMPLETO DE PERFIL A CLIP, JAMBA Y PUERTA BATIENTE - KIT COMPLET AVEC PROFIL A CLIPSEUR, CADRE DE PORTE AVEC PAUMELLES

<b>SET =</b>	<b>P-030</b>	<b>+</b>	<b>P-088</b>	<b>+</b>	<b>DIV-100</b>	<b>+</b>	<b>DIV-058</b>	<b>+</b>	<b>DIV-208 (optional)</b>	<b>+</b>	<b>DIV-204 (optional)</b>
	Door jamb Zarge Jamba de puerta Montant de porte		Pair clip-on profiles for fixed panel Paar Klipsprofile für Festteil Par de junquillos Profil a clipser pour panneau fixe		Hinged framed panel Gerahmte Dreh-Tür Panel batiente enmarcado Cadre avec paumelles		Clip-on profile Klipsprofil Perfil a clip Profil a clipser		H profile H Profil Perfil "H" Profil en H		Cross profile Querprofil Travesaño Traverse

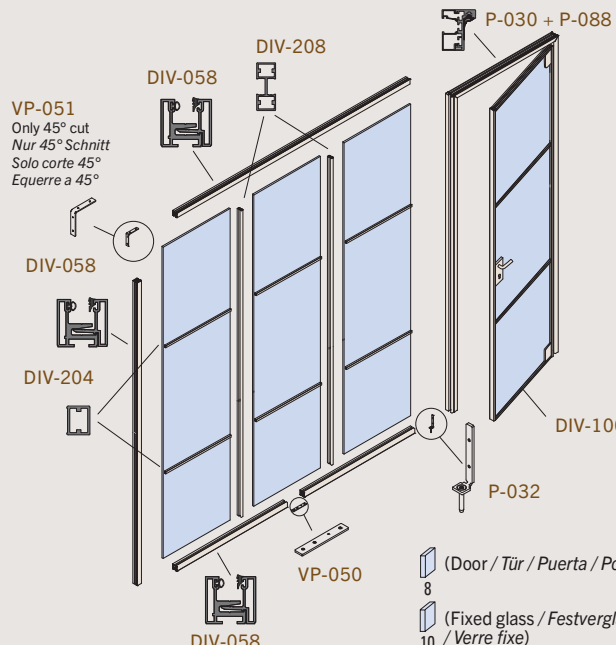
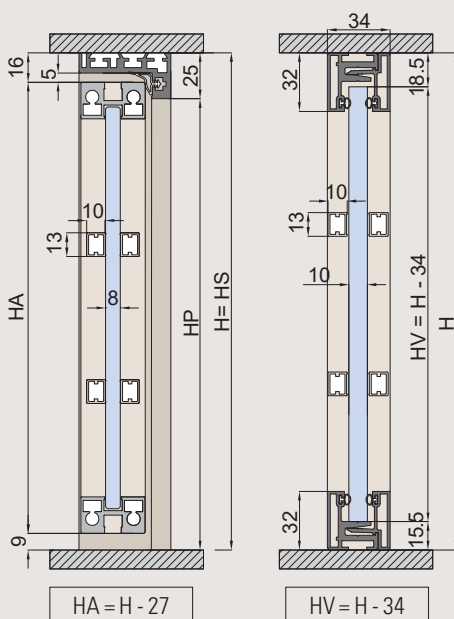
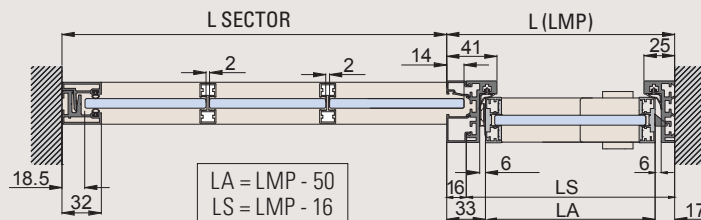
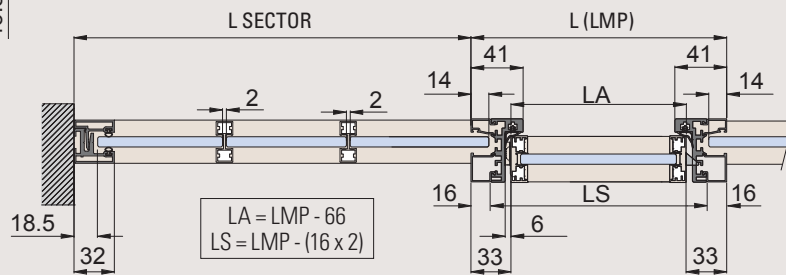
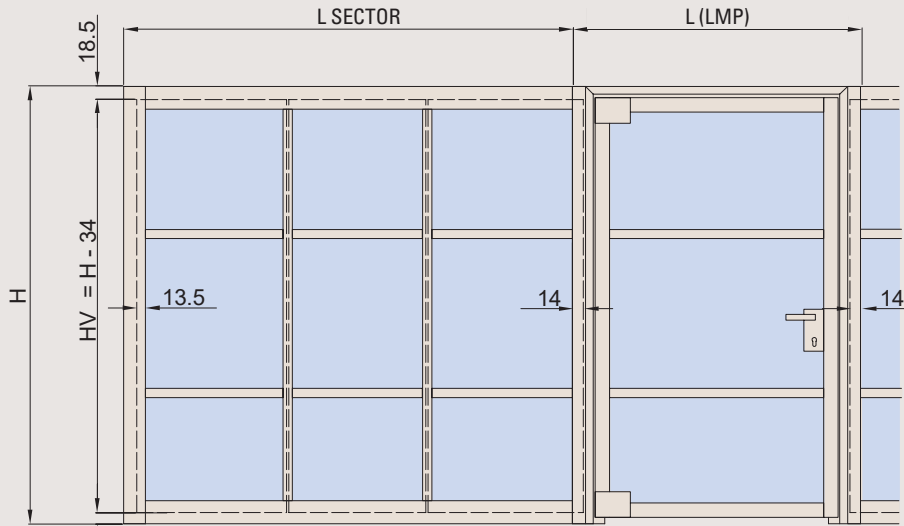

8 (Door / Tür / Puerta / Porte)

10 (Fixed glass / Festverglasung / Vidrio fijo / Verre fixe)

xme620c / xme620x

# DIV-058

CLIP-ON PROFILES FOR FIXED PANELS - KLIPSPROFILE FÜR FESTVERGLASUNGEN  
 PERFIL DE CLIP PARA VIDRIOS FIJOS - PROFIL A CLIPSER POUR PANNEAU FIXE



## MY METALGLAS

Configure your panel to calculate the cross profiles  
 Konfigurieren Sie Ihre Tür und berechnen Sie automatisch die Querprofile  
 Componga su puerta para cuantificar los travesaños por encargo  
 Composez votre porte pour quantifier les traverses à commander

### DIV-058

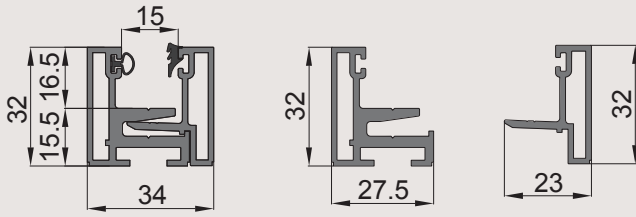

Gaskets for glass 10 mm  
 Dichtungen für Glas 10 mm  
 Guarnición para vidrio 10mm  
 Joint pour verre de 10 mm

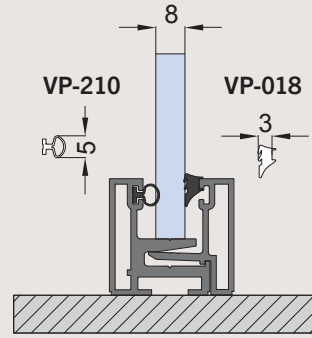
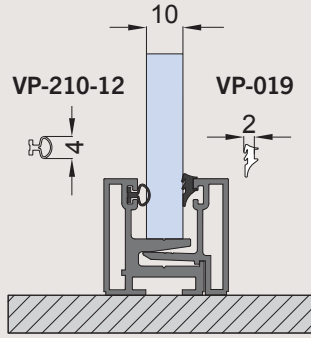

Gaskets for glass 8 mm  
 Dichtungen für Glas 8 mm  
 Guarnición para vidrio 8 mm  
 Joint pour verre de 8 mm

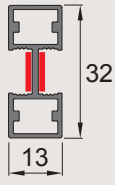

**DIV-208**  
 "H" profile Glass-Glass  
 "H" Profil Glas-Glas  
 Perfil "H" vidrio - vidrio  
 "H" profil verre verre

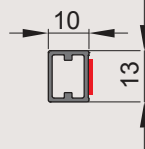

**DIV-204**  
 Cross profile  
 Querprofil  
 Travesaño  
 Traverse

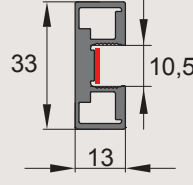

**DIV-202**  
 Finishing profile  
 Abschlussprofil  
 Perfil de acabado  
 Profil de finition

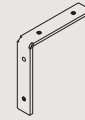

**VP-051**  
 Only 45° cut  
 Nur 45° Schnitt  
 Solo corte 45°  
 Equerre a 45°

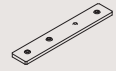

**VP-050**

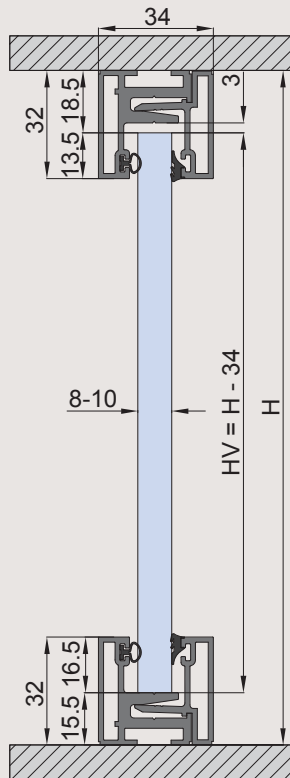

$$HV = H - 34$$

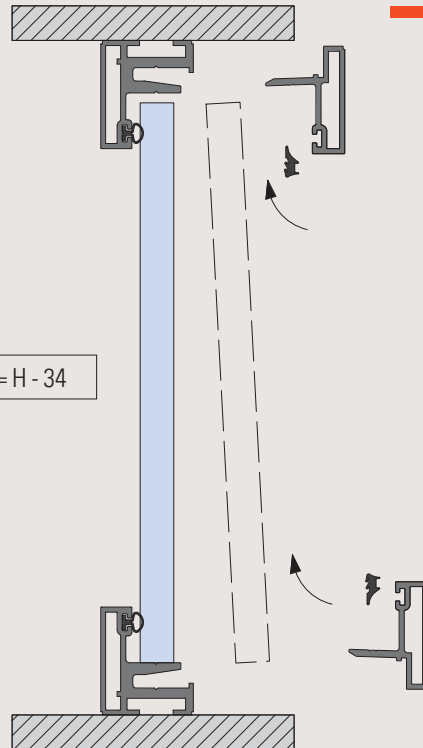

Pre-installed double-sided adhesive  
 Selbstklebend  
 Bi-adhesivo  
 preinstalado  
 Ruban adhésif double face préinstallé

xme620a

# DIV-100



HINGED FRAMED PANEL

GERAHMTE DREHTÜR - PANEL DE PUERTA BATIENTE ENMARCADA - CADRE AVEC PAUMELLES

Door / Tür / Puerta / Porte **DIV-100**

Max 

55 kg

 8  
 950 max



## DIV-100

Framed panel set max 950 x 2980 mm (lock not included)

Gerahmte Drehtür-Set max 950 x 2980 mm (Schloss nicht enthalten)

Set de puerta enmarcada, max 950 x 2980 mm (cerradura no incluida)

Kit cadre avec paumelles max 950 mm x 2980 mm (serrure en option)

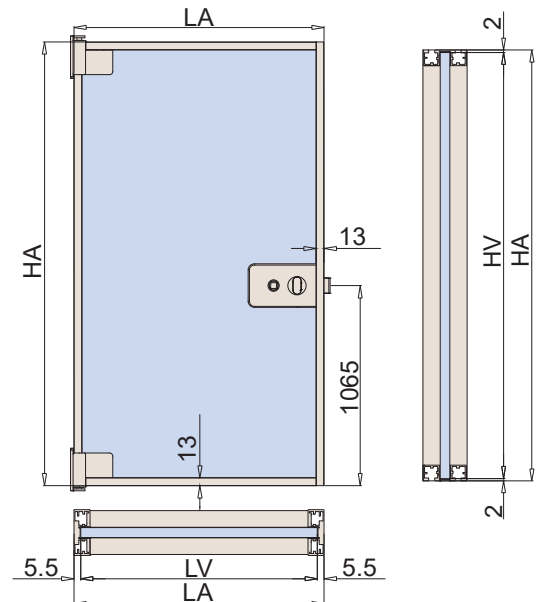

$$LV = LA - 11$$

$$HV = HA - 4$$

**DIV-V742**  
Pair hinges  
Paar Bänder  
Par de bisagras  
Paire de paumelles

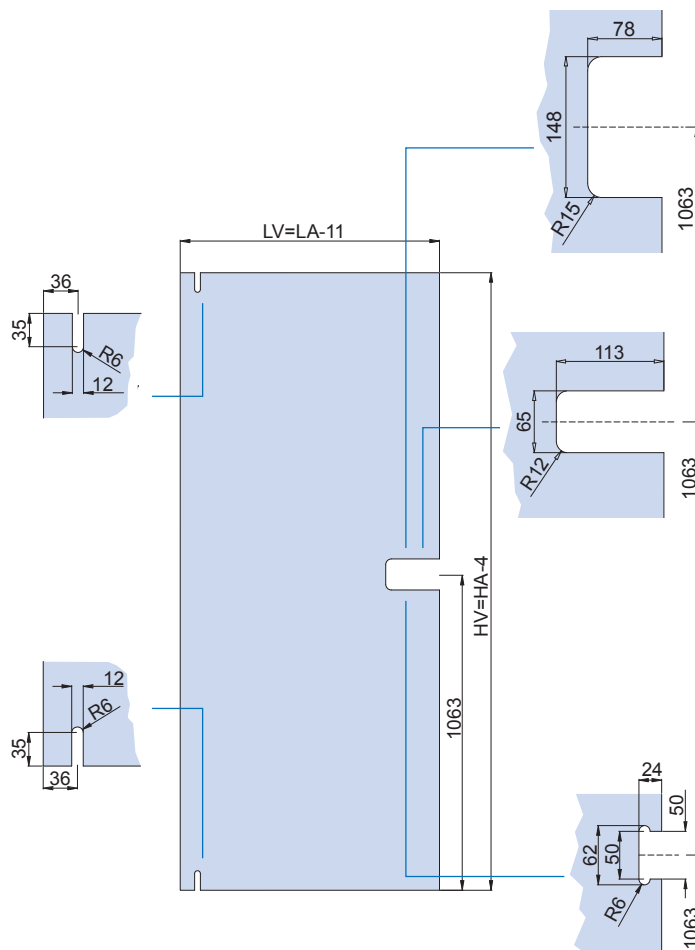
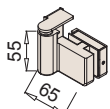

**V-741 PZ / MV-741 PZ**   
Vertical lock  
Vertikales schloss  
Cerradura vertical  
Serrure verticale

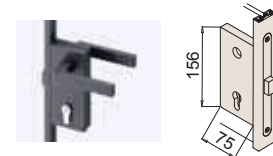

**V-740 UV / MV-740 UV**   
Compacted lock  
Kompaktes Schloss UV  
Cerradura compacta  
Serrure compacte



**V-740 WC / MV-740 WC**   
Horizontal lock WC  
Horizontalschloss WC  
Cerradura horizontal WC  
Serrure horizontale WC

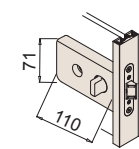
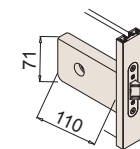

**DIV-M101**  
Magnetic small handle  
Kleine Magnetgriffe  
Manilla compacta magnética  
Petite poignée aimantée

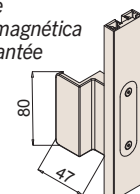

xme636a/g/u

# STIPITI P-030/TP-150

DOOR JAMBS FOR FRAMED HINGED DOOR

ZARGEN FÜR GERÄHMTE DREHTÜR - JAMBAS DE PUERTA PARA PUERTAS BATIENTES ENMARCADAS - ENCADREMENT POUR PORTE À CADRE



**P-030/P-031**  
Door jamb / Zarge - Jamba de puerta - Encadrement



**P-012-CF4**

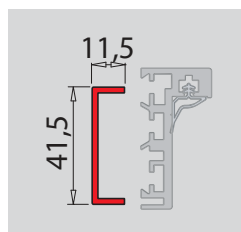

Optional wall profile for adjustment P-033  
Wandprofil für Verstellung P-033  
Perfil a muro para regulación P-033 opcional  
Profil d'alignement mural P-033 en option

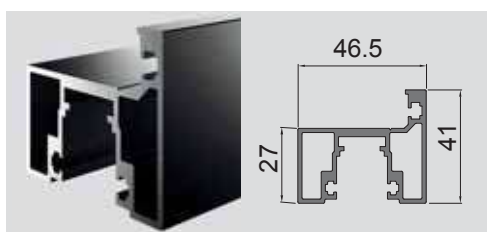

**TP-150**  
Door jamb / Zarge - Jamba de puerta - Encadrement

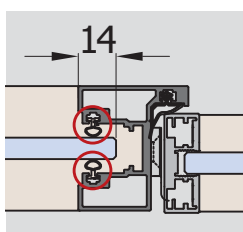

**B-146**  
Glass gaskets mm 8/10 mm  
Glasdichtungen mm 8/10 mm  
Guarnición mm 8/10  
Joint pour verre de 8/10 mm

**VP-210-12**  
Glass gaskets mm 12/12.76/13.5  
Glasdichtungen mm 12/12.76/13.5  
Guarnición mm 12/12.76/13.5  
Joint pour verre de 12/12,76/13,5



# FRAMED HINGED DOOR DIV-100

FRAMED SLIDING DOOR DIV - FORMULAS FOR CONFIGURATION OF THE CROSS PROFILES (V AND VL ARE VALUES ONLY FOR CALCULATION)  
 GERAHMTE SCHIEBETÜR DIV - FORMELN FÜR KONFIGURATION VON QUERPROFILE (V UND VL SIND WERTE NUR FÜR DIE BERECHNUNG)  
 PUERTA DESLIZANTE ENMARCADA - FORMULAS PARA CONFIGURACIÓN DE LISTONES (V Y VL SON LOS VALORES ÚNICAMENTE PARA EL CÁLCULO)  
 PORTE A CADRE SUR PAUMELLES DIV-100 FORMULE POUR LA CONFIGURATION DES TRAVERSES (V ET VL SONT DES VALEURS UNIQUEMENT POUR LE CALCUL)

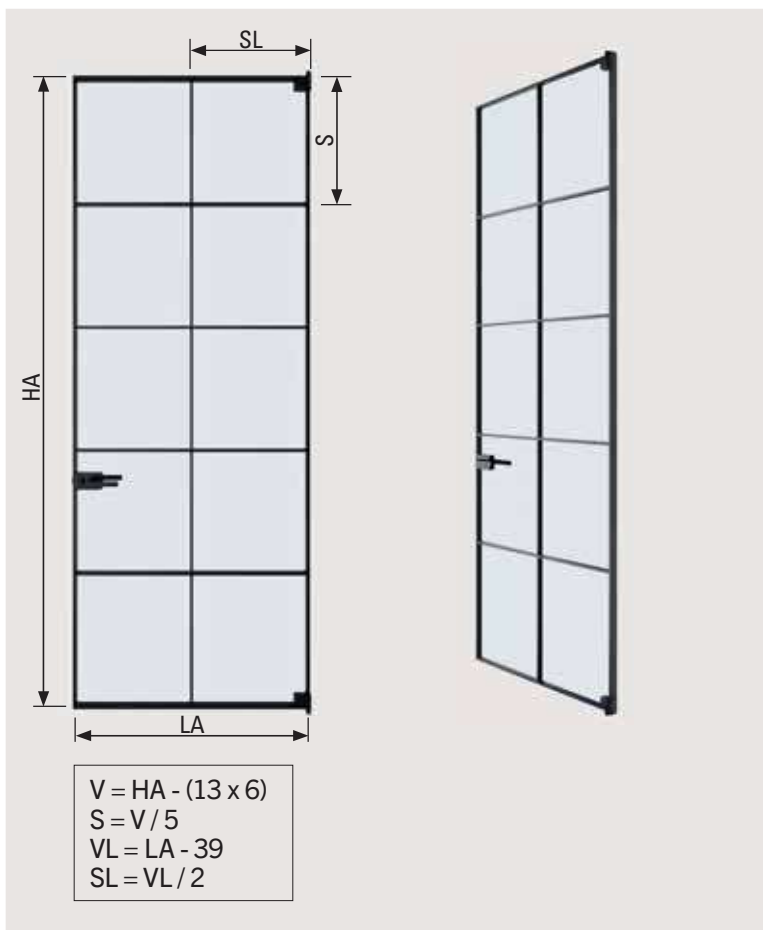
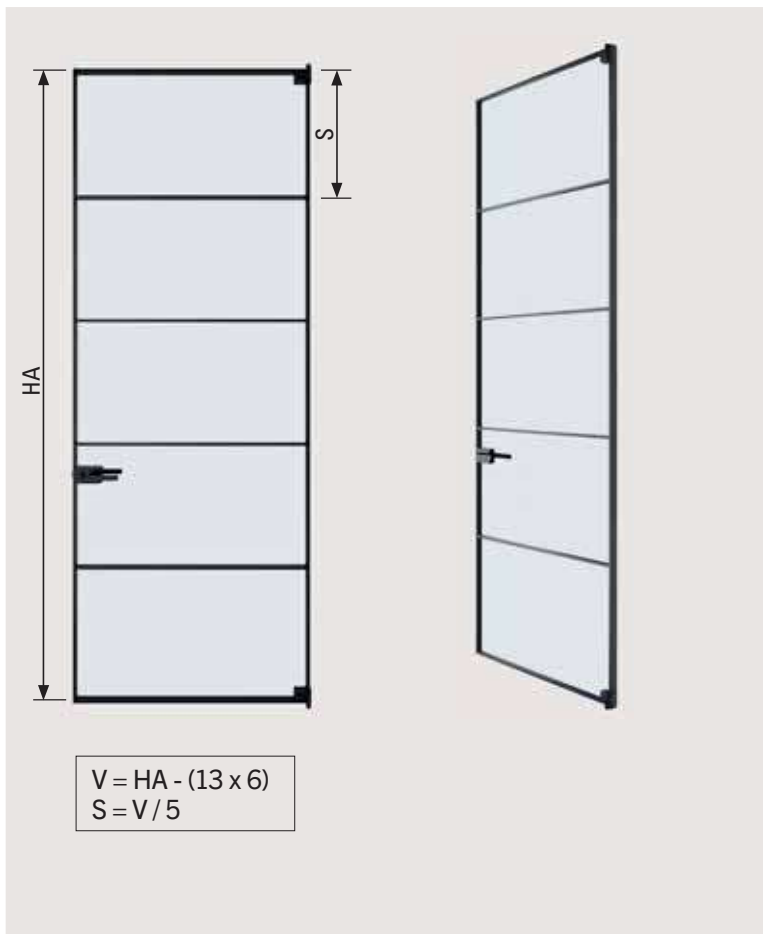

## MY METALGLAS

Configure your panel to calculate the cross profiles  
Konfigurieren Sie Ihre Tür und berechnen Sie automatisch die Querprofile  
Componga su puerta para cuantificar los travesaños por encargo  
Composez votre porte pour quantifier les traverses à commander

