

# BAIA DI PARCHEGGIO / STACKING ARRANGEMENTS / PARKSITUATIONEN

## ESEMPI / EXAMPLES / BEISPIELE

SCORREVOLI A PARCHEGGIO  
SLIDING STACKING SYSTEMS

**A1** PA-108 DX  
PA-108 SX

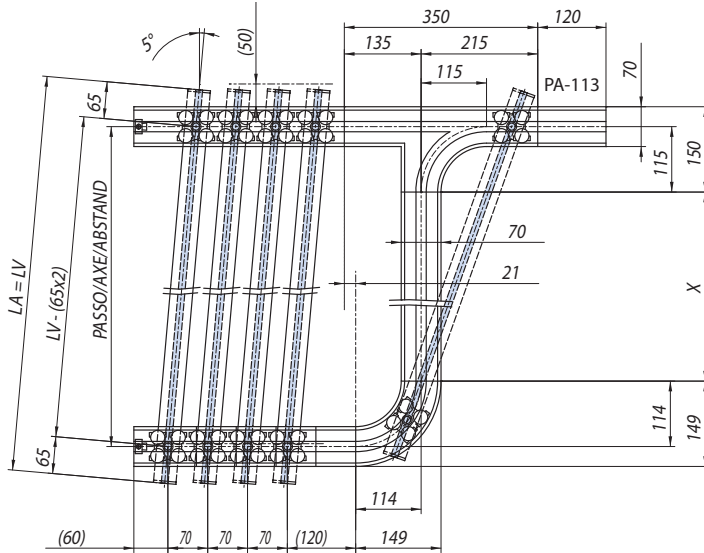

- Vista dall'alto (da sopra il profilo guida)
- View from above the rail
- Sicht von oben über der Laufschiene

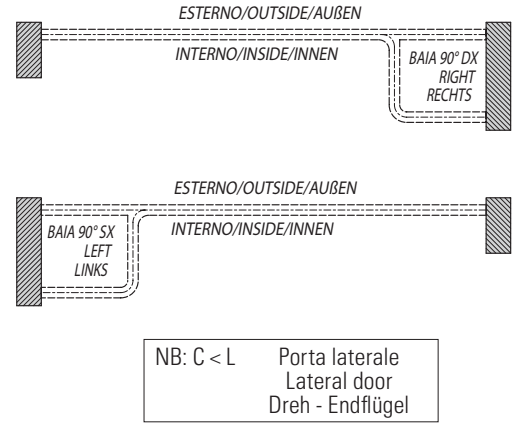

xla167\_0

**A2** PA-109 DX  
PA-109 SX

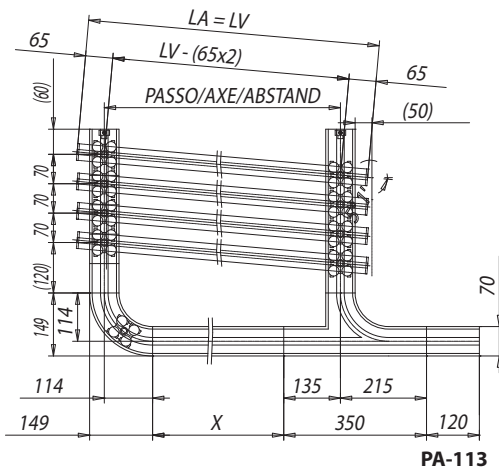

- Vista dall'alto (da sopra il profilo guida)
- View from above the rail
- Sicht von oben über der Laufschiene

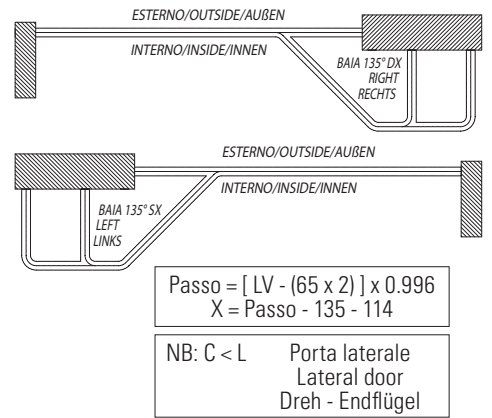

xla167\_1

**D** PA-119-D DX  
PA-119-D SX

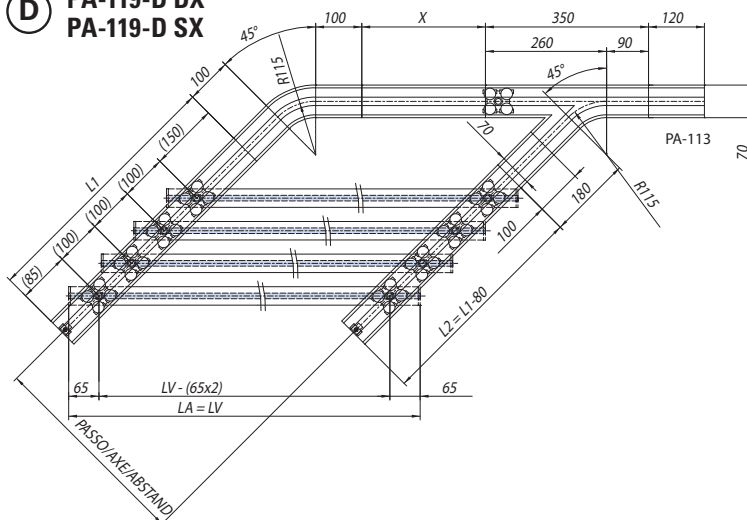

- Vista dall'alto (da sopra il profilo guida)
- View from above the rail
- Sicht von oben über der Laufschiene

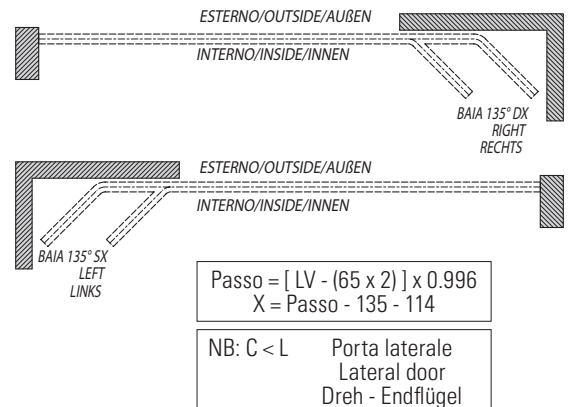

xla167\_0

# BAIA DI PARCHEGGIO / STACKING ARRANGEMENTS / PARKSITUATIONEN

## ESEMPI / EXAMPLES / BEISPIELE

### L PA-119-L DX PA-119-L SX

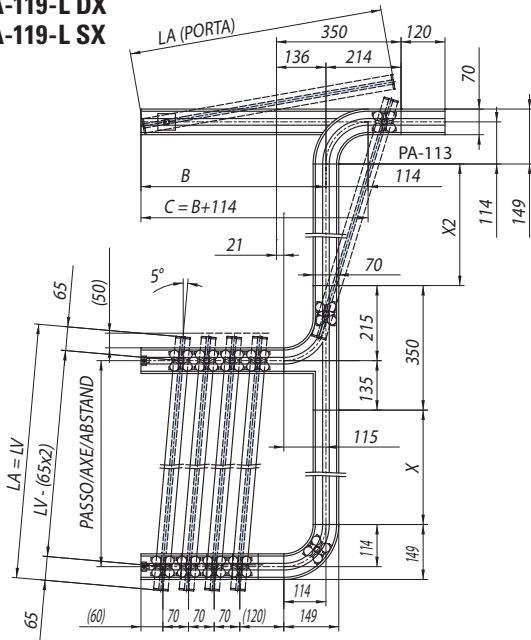

- Vista dall'alto (da sopra il profilo guida)
- View from above the rail
- Sicht von oben über der Laufschiene

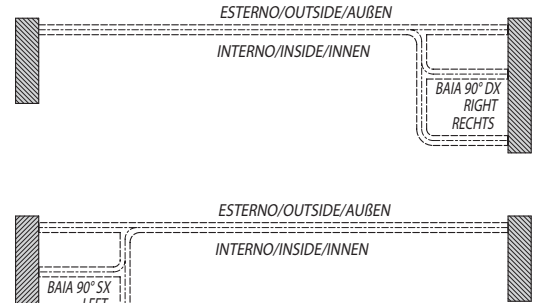

$$\text{Passo} = [LV - (65 \times 2)] \times 0.996$$

$$X = \text{Passo} - 135 - 114$$

NB: C < L Porta laterale  
Lateral door  
Dreh - Endflügel

xla167\_0

### H PA-119-H DX PA-119-H SX

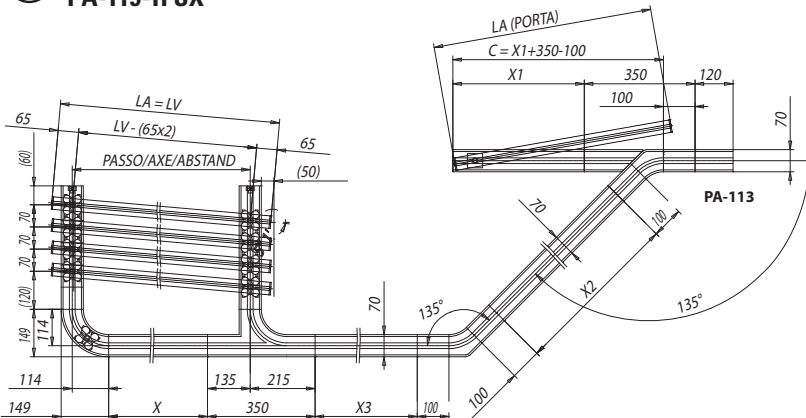

- Vista dall'alto (da sopra il profilo guida)
- View from above the rail
- Sicht von oben über der Laufschiene

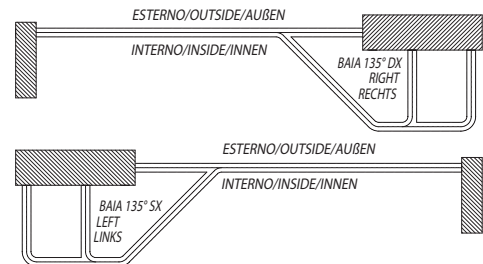

$$\text{Passo} = [LV - (65 \times 2)] \times 0.996$$

$$X = \text{Passo} - 135 - 114$$

NB: C < L Porta laterale  
Lateral door  
Dreh - Endflügel

xla 167\_1

### O PA-119-O DX PA-119-O SX

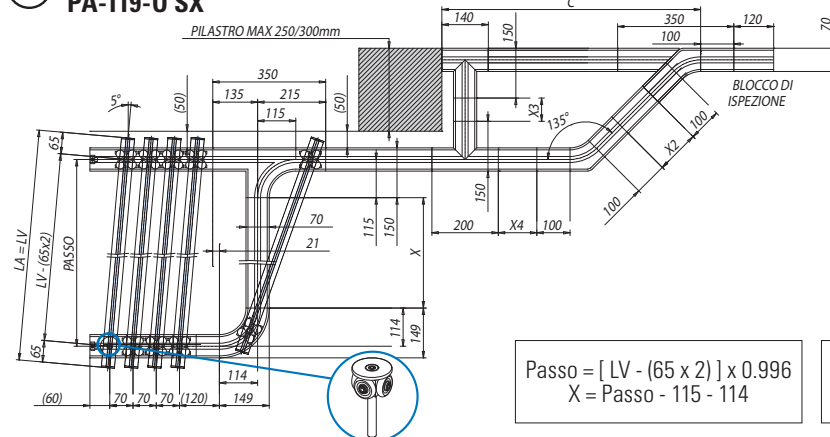

- Vista dall'alto (da sopra il profilo guida)
- View from above the rail
- Sicht von oben über der Laufschiene

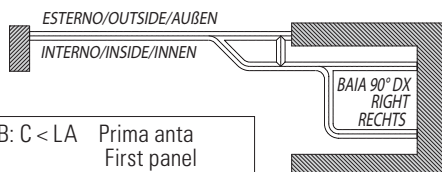
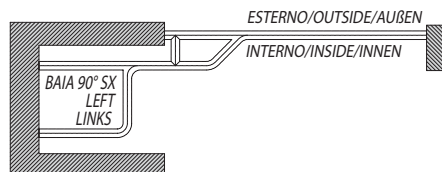

$$\text{Passo} = [LV - (65 \times 2)] \times 0.996$$

$$X = \text{Passo} - 115 - 114$$

NB: C < LA Prima anta  
First panel  
Erster-Schiebeflügel

xla 167\_f

**Passo**  
Interasse carrelli  
Axe  
Abstand

**LA = LV**  
Larghezza ante = Larghezza vetro  
Panel width = Glass width  
Flügelbreite = Glasbreite

# BAIA DI PARCHEGGIO / STACKING ARRANGEMENTS / PARKSITUATIONEN

## ESEMPI / EXAMPLES / BEISPIELE

SCORREVOLI A PARCHEGGIO  
SLIDING STACKING SYSTEMS

**B** PA-119-B-DX  
PA-119-B-SX

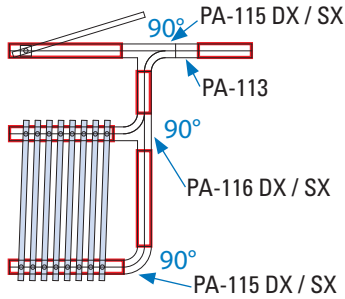

**C** PA-119-C-DX  
PA-119-C-SX

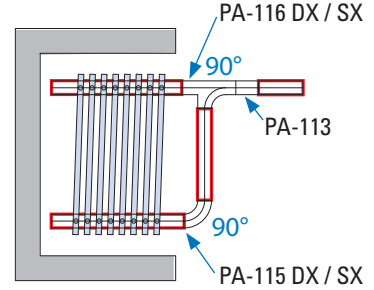

**D** PA-119-D-DX  
PA-119-D-SX

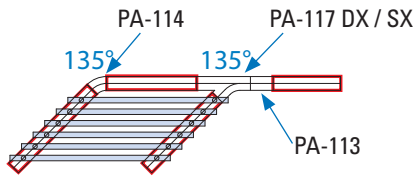

**F** PA-119-F-DX  
PA-119-F-SX

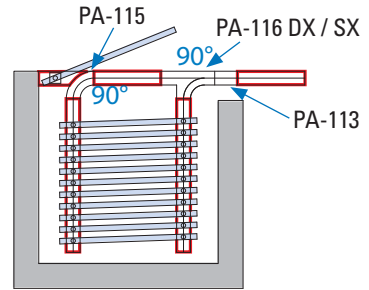

**I** PA-119-I-DX  
PA-119-I-SX

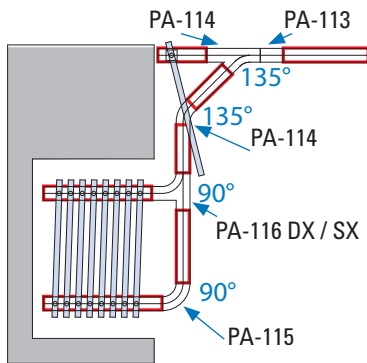

**L** PA-119-L-DX  
PA-119-L-SX

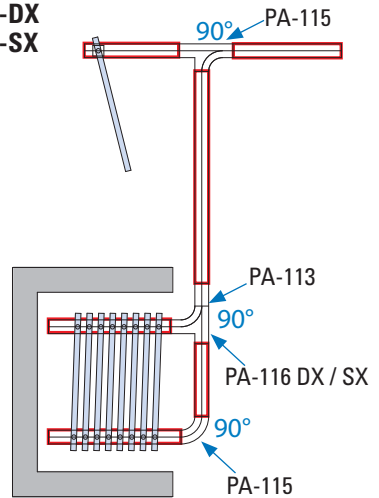

**M** PA-119-M-DX  
PA-119-M-SX

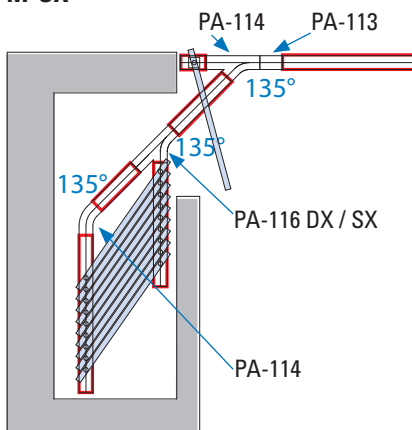

**N** PA-119-N-DX  
PA-119-N-SX

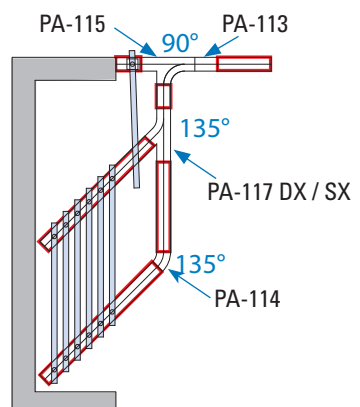

# BAIA DI PARCHEGGIO / STACKING ARRANGEMENTS / PARKSITUATIONEN

## COMPONENTI / COMPONENTS / EINZELTEILE

**G** PA-119-G-DX  
PA-119-G-SX

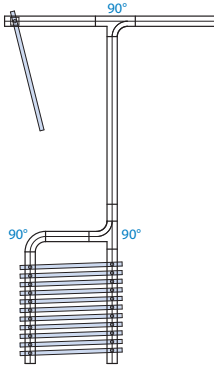

**P** PA-119-P-DX  
PA-119-P-SX

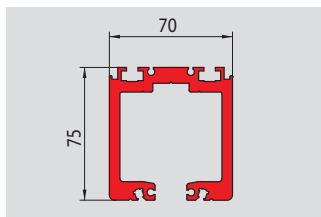
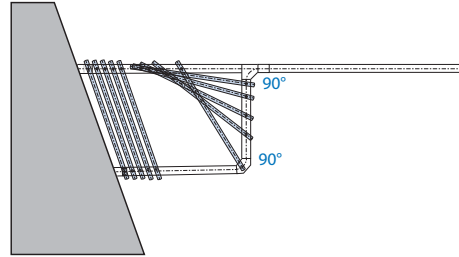

**PA-100**

- Binario superiore di scorrimento in alluminio anodizzato
- Anodised aluminium top track profile
- Natureloxierten Aluminium Laufschieneprofil

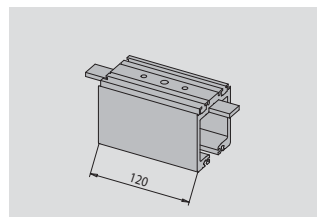

**PA-113**

- Pezzo profilo per apertura manutenzione
- Profile piece for maintenance
- Revisionsstück

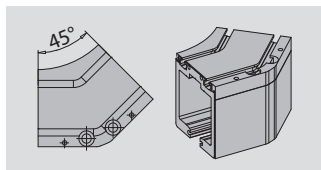

**PA-114**

- Curva 45°
- Curved section 45°
- Modul für 45° Winkel

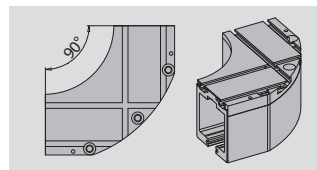

**PA-115**

- Curva 90°
- Curved section 90°
- Modul für 90° Winkel

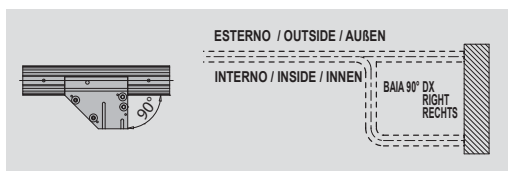

**PA-116 DX**

- Scambio 90° destro
- 90° angle right
- 90° Abzweig rechts

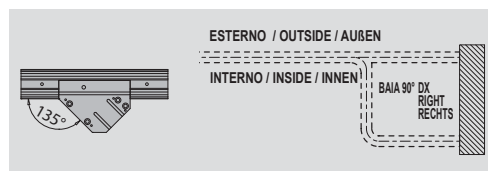

**PA-117 DX**

- Scambio 135° destro
- 135° T-piece right
- T-Stück/Abzweig 135° rechts

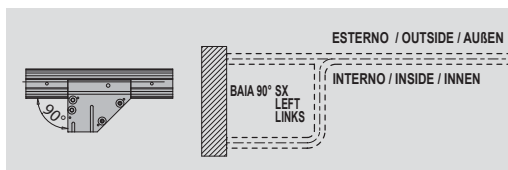

**PA-116 SX**

- Scambio 90° sinistro
- 90° angle left
- 90° Abzweig links

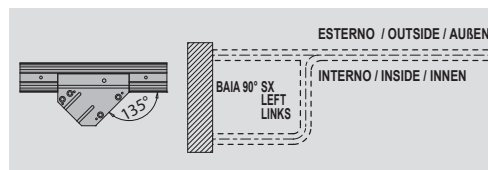

**PA-117 SX**

- Scambio 135° sinistro
- 135° T-piece left
- T-Stück/Abzweig 135° links

